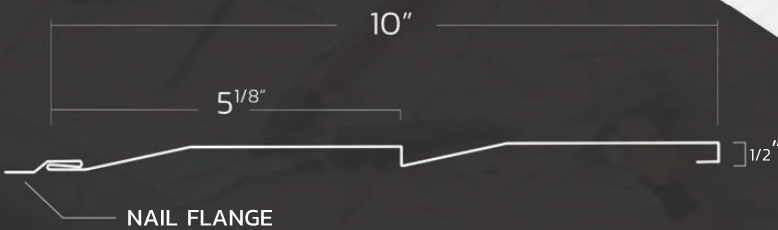
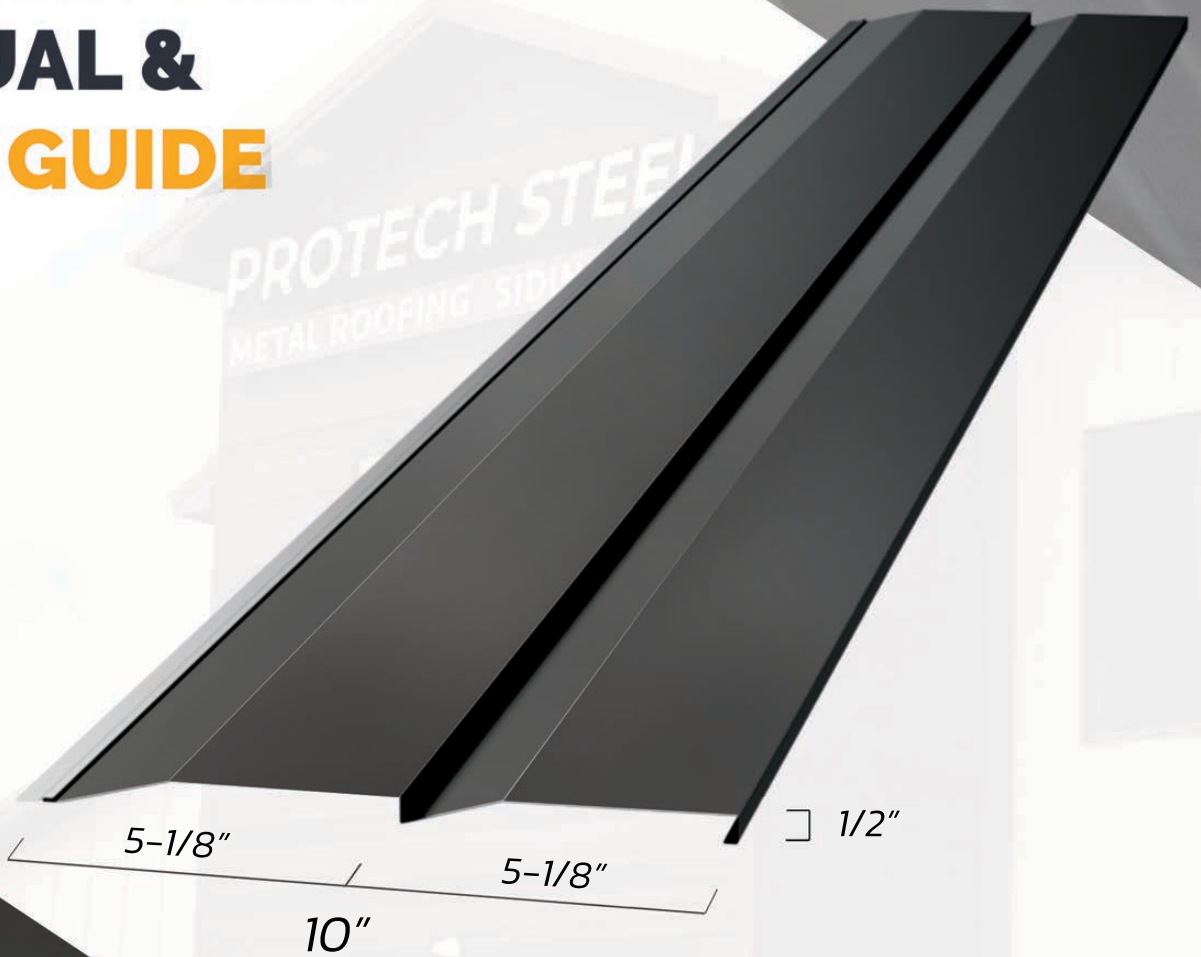




**DOUBLE 5"
DUTCH LAP**

**INSTALLATION
MANUAL &
USER GUIDE**



PROTECH STEEL GUIDE OVERVIEW

THE DRAWINGS AND ILLUSTRATIONS IN THIS MANUAL ARE PROVIDED FOR REFERENCE PURPOSES ONLY AND MAY NOT BE SUITABLE FOR ALL BUILDING DESIGNS OR PRODUCT INSTALLATIONS. ALL PROJECTS MUST COMPLY WITH THE SPECIFIC BUILDING CODES APPLICABLE TO THEIR LOCATION. IT IS ESSENTIAL TO ADHERE TO ALL RELEVANT BUILDING REGULATIONS AND INDUSTRY BEST PRACTICES.

PROTECH STEEL WILL NOT BE HELD ACCOUNTABLE FOR THE PERFORMANCE OF THE WALL SYSTEM IF IT IS NOT INSTALLED IN ACCORDANCE WITH THE RECOMMENDATIONS IN THIS MANUAL. IN INSTANCES WHERE THERE IS A DISCREPANCY BETWEEN THIS MANUAL AND THE ACTUAL ERECTION DRAWINGS, THE ERECTION DRAWINGS SHOULD TAKE PRECEDENCE. ALL COLORS MUST BE CHOSEN FROM STEEL SAMPLES AND NOT PRINT OR ONLINE.

BEFORE ORDERING AND INSTALLING MATERIALS, ENSURE THAT ALL DIMENSIONS ARE CONFIRMED WITH FIELD MEASUREMENTS TO ENSURE ACCURACY.

PROTECH STEEL RESERVES THE RIGHT TO AMEND ANY DETAILS, RECOMMENDATIONS, OR SUGGESTIONS WITHOUT PRIOR NOTICE. IF YOU HAVE ANY QUESTIONS REGARDING THE SUCCESSFUL INSTALLATION OF THESE WALL PANEL SYSTEMS, PLEASE CONTACT YOUR LOCAL PROTECH STEEL REPRESENTATIVE. PRIOR STEEL KNOWLEDGE REQUIRED FOR PROPER INSTALLATION.

OIL CANNING, WHICH IS THE VISIBLE WAVINESS IN THE FLAT AREAS OF METAL PANELS, IS NOT CONSIDERED A DEFECT. IT IS A NATURAL CHARACTERISTIC OF LIGHT GAUGE COLD-FORMED METAL PRODUCTS, ESPECIALLY THOSE WITH BROAD, FLAT SURFACES. VARIOUS FACTORS CAN CONTRIBUTE TO OIL CANNING THAT ARE BEYOND THE CONTROL OF PROTECH STEEL, INCLUDING: MISALIGNMENT OF THE SUPPORT SYSTEM, OVER-DRIVING FASTENERS, STRESS WITHIN OR INDUCED INTO THE PANEL, THERMAL EXPANSION AND CONTRACTION, IMPROPER MATERIAL HANDLING, PANEL WIDTH, GAUGE, LENGTH, AND COLOR. SPEAK WITH ONE OF OUR PROJECT PROFESSIONALS ABOUT OILCANNING AND WAYS TO AVOID IT.

FOR ANY ADDITIONAL INFORMATION NOT COVERED IN THIS MANUAL, CONSULT YOUR LOCAL PROTECH STEEL BRANCH. THIS MANUAL IS INTENDED FOR INDUSTRY PROFESSIONALS, TO SERVE AS A GUIDE FOR SUCCESSFULLY INSTALLING A WALL PANEL SYSTEM. IT IS THE RESPONSIBILITY OF THE PROFESSIONAL OR COMPETENT INSTALLER TO ENSURE THE SAFE AND PROPER INSTALLATION OF THE PRODUCT.

FOR MORE INFORMATION OR QUESTIONS REGARDING THE INSTALLATION OF WALL PANEL SYSTEMS, CONTACT YOUR LOCAL PROTECH STEEL REPRESENTATIVE AT **1-888-21-STEEL** OR **INFO@PROTECHSTEEL.COM**.

PROTECH STEEL MATERIAL GUIDELINES

PREPARATION

BEFORE STARTING PANEL INSTALLATION, PLAN THE LAYOUT FOR ALIGNMENT WITH ADJACENT WALL SECTIONS. DECIDE IF THE FIRST PANEL WILL BE A FULL OR PARTIAL PANEL. CONSIDER THE LOCATIONS OF WALL PENETRATIONS, OPENINGS, AND THE EDGES OF THE WALL PLANE TO ENSURE A COHESIVE AND PLANNED APPROACH.

ORDER ACCURACY

UPON RECEIVING MATERIALS, VERIFY THAT ALL PARTS ARE INCLUDED AND UNDAMAGED. REPORT ANY SHORTAGES IMMEDIATELY TO YOUR PROTECH STEEL CONTACT. NOTE ANY TRANSIT DAMAGE ON THE BILL OF LADING TO ENSURE ACCOUNTABILITY AND RESOLUTION.

SAFETY PRECAUTIONS

ENSURE TO USE APPROPRIATE SAFETY GEAR, EQUIPMENT, AND PROCESSES DURING INSTALLATION. ESSENTIAL SAFETY GEAR INCLUDES GLOVES, ARM GUARDS, SAFETY GOGGLES, AND FALL PROTECTION. USE WELL-MAINTAINED TOOLS SUCH AS SCREW GUNS, SAWS, SNIPS, AND FOLDERS. ALWAYS BE AWARE OF POTENTIAL HAZARDS AND TAKE NECESSARY PRECAUTIONS TO AVOID ACCIDENTS.

MATERIAL

NOT ALL PANELS, TRIM, TGAUGES OR LENGTHS ARE AVAILABLE AT EVERY LOCATION. CUSTOM COLORS AND NON-STANDARD MATERIALS ARE SOMETIMES SECURED PER PROJECT AND REQUIRE MINIMUM ORDER QUANTITIES. VERIFY MATERIAL AVAILABILITY WITH YOUR PROTECH STEEL REPRESENTATIVE.

MATERIAL STORAGE

STORE MATERIALS INDOORS AWAY FROM THE ELEMENTS IF THEY ARE NOT IMMEDIATELY NEEDED. IF INDOOR STORAGE IS UNAVAILABLE, COVER THE MATERIALS WITH A TARP THAT ALLOWS AIR CIRCULATION. ELEVATE CRATES OFF THE GROUND AND POSITION THEM AT A SLOPE TO ENSURE WATER RUNOFF. READ AND ADHER TO ALL LABELS AND CAUTIONS ON PROTECH STEEL MATERIAL.

HANDLING MATERIAL

TRANSPORT PANELS IN THEIR CRATES / STACKS TO THE INSTALLATION SITE. PROVIDE ADEQUATE SUPPORT FOR INDIVIDUAL PANELS EVERY 6 TO 8 FEET. HANDLE PANELS CAREFULLY BY GRASPING ONE SIDE AND ALLOWING THE OTHER SIDE TO HANG DOWN TO PREVENT BENDING OR WARPING.

PRE INSTALLATION INSPECTION

BEFORE INSTALLING PANELS, ENSURE THE WALL SUPPORT STRUCTURE IS PLUMB, SQUARE, AND TRUE. ANY VARIANCE FROM THE PLANE SHOULD NOT EXCEED 1/4" OVER 10 FEET. PROPER ALIGNMENT ENSURES A SEAMLESS AND PROFESSIONAL INSTALLATION. PROPER PLANNING CAN SAVE TIME AND TROUBLE DOWN THE ROAD.

PROPER DRY-IN

COVER THE BUILDING ENVELOPE SHEATHING WITH A MOISTURE BARRIER LIKE PROTECH STEEL SYNTHETIC UNDERLAYMENT OR PEEL AND STICK BUILDING WRAP TO RESIST AIR AND WATER PENETRATION. INSTALL THE MOISTURE BARRIER HORIZONTALLY, STARTING FROM THE BOTTOM AND OVERLAPPING EACH LAYER ABOVE THE PREVIOUS ONE TO ENSURE PROPER WATER SHEDDING.

FASTENERS

AVOID OVER-TIGHTENING FASTENERS, WHICH CAN DEFORM PANELS AND TRIM. FASTENERS SHOULD SECURE THE MATERIAL JUST ENOUGH TO MAKE FIRM CONTACT BETWEEN THE SUPPORT STRUCTURE, PANEL, AND TRIM. FOLLOW THE RECOMMENDED FASTENING PATTERNS AND DETERMINE FASTENER SPACING BASED ON A LOAD ANALYSIS TO ENSURE SECURE ATTACHMENT.

INSTALLATION PROTOCOL

FOR HORIZONTAL PANEL INSTALLATIONS, BEGIN AT THE BOTTOM AND WORK UPWARDS, ENSURING EACH PANEL OVERLAPS THE ONE BELOW TO ALLOW WATER RUNOFF. ENSURE ALL SURFACES HAVE AN ADEQUATE SLOPE TO PREVENT WATER ACCUMULATION. VERTICAL PANELS CAN BE INSTALLED FROM RIGHT-TO-LEFT OR LEFT-TO-RIGHT. REGULARLY CHECK FOR PROPER MODULE COVERAGE TO MAINTAIN ALIGNMENT.

PLASTIC WRAP

PANELS AND TRIM ARE OFTEN PROVIDED WITH A PLASTIC FILM TO PROTECT AGAINST MINOR DAMAGE DURING FABRICATION, TRANSIT, AND HANDLING. REMOVE THE FILM JUST BEFORE INSTALLATION. DELAYING REMOVAL UNTIL AFTER INSTALLATION OR PROLONGED EXPOSURE TO SUNLIGHT OR HEAT CAN MAKE THE FILM DIFFICULT TO REMOVE.

FOLLOWING THESE GUIDELINES ENSURES A SMOOTH INSTALLATION PROCESS AND MAINTAINS THE INTEGRITY AND APPEARANCE OF YOUR PROTECH STEEL PANELS.



DISCLAIMER: OIL CANNING IS A NATURAL COSMETIC PHENOMENON THAT DOES NOT IMPACT PANEL PERFORMANCE. IT IS MINIMIZED BY STRIATIONS ON PANELS OVER 10" AND MATTE FINISHES.



OIL CANNING

Oil canning is a natural, cosmetic phenomenon in metal panel systems that manifests as subtle waviness or “oil-can” distortions across the flat areas of a panel. It occurs primarily **due to thermal expansion** and contraction, variations in substrate flatness, and differences in tension during manufacture and installation. While **oil canning does not affect the structural performance** or weather-tightness of your roof or wall system, **we strongly recommend the following** measures to minimize its visibility:

- **Striations:** Adding light striations or V-grooves to the panel surface helps break up reflections and significantly reduces the appearance of oil canning. In fact, any batten-style panel wider than 10" must include striations as a standard feature.
- **Finish Selection:** A matte or low-gloss finish is less prone to highlight surface irregularities than high-gloss coatings—choosing a matte finish can further diminish the perception of waviness.
- **Proper Installation:** Allow for uniform panel expansion by following manufacturer recommendations for clip spacing, fastener placement, and substrate preparation. Ensuring a level, continuous substrate and avoiding over-tightening of fasteners will help panels move freely and reduce stress.

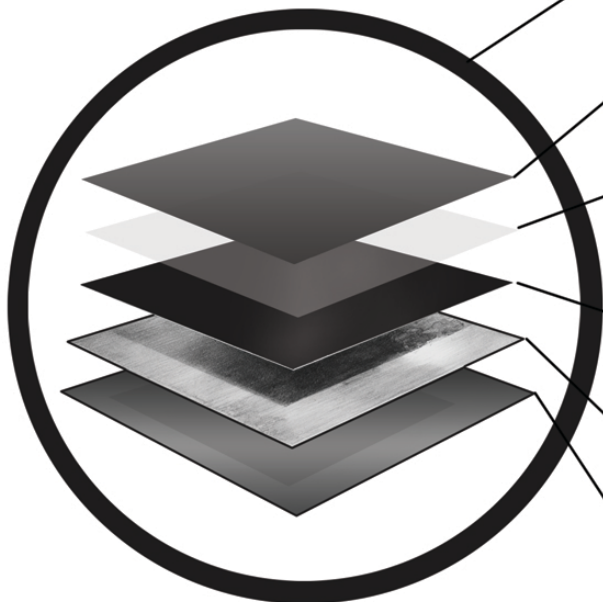
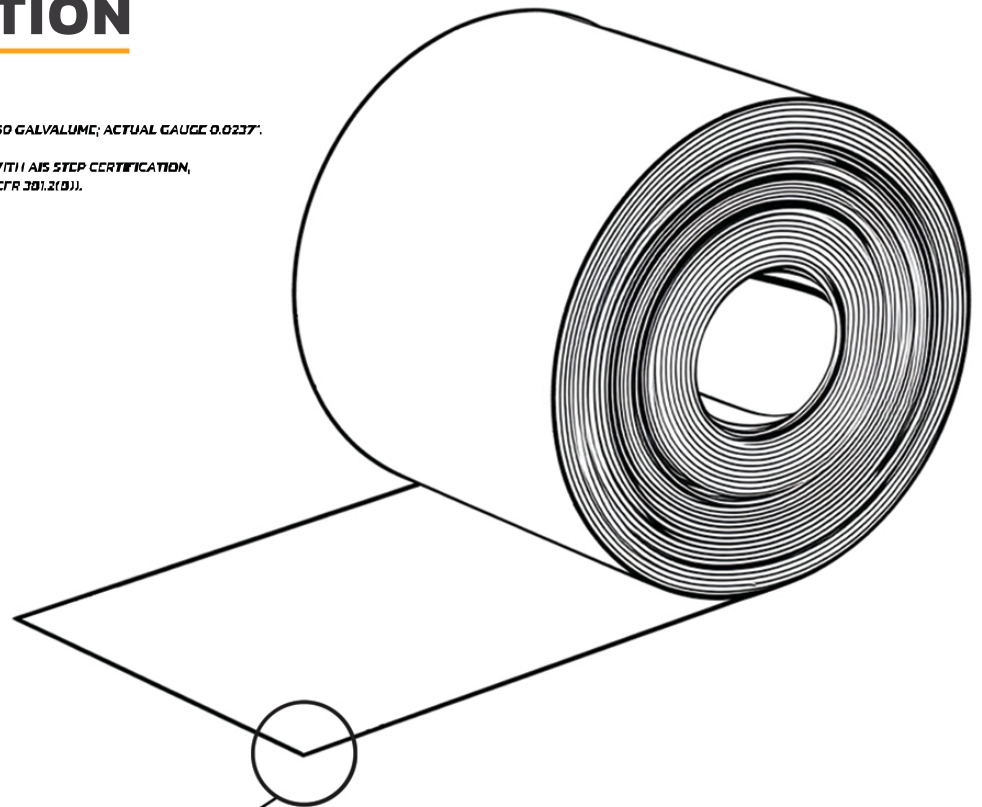
By specifying striated profiles on wide panels, opting for matte finishes, and adhering to installation best practices, you can achieve a visually smooth, high-quality metal surface that stands up to thermal cycling without drawing attention to oil canning.

 **STEEL COIL INFORMATION**

STEEL COIL INFORMATION

24 GA GR50 (ASTM A792 SS GRADE 50 CLASS 4) WITH AZ50 GALVALUME; ACTUAL GAUGE 0.0237.

MELTED AND MANUFACTURED IN THE USA; COMPLIANT WITH AISI STEEL CERTIFICATION, BUY AMERICA (23 CFR 635.410) AND BUY AMERICAN (46 CFR 301.21(B)).



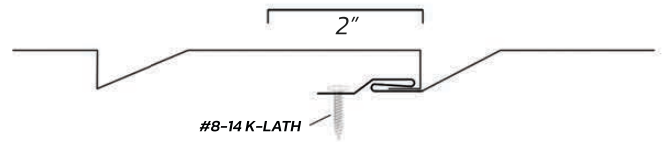
TOP COAT (PVDF): PVDF COLOR TOPCOAT FOR EXTERIOR DURABILITY AND COLOR HOLDOUT.

PRIMER: COIL-COAT PRIMER UNDER THE PVDF TO PROMOTE ADHESION AND CORROSION HOLDOUT (STANDARD PREPAINTED SYSTEM).

TREATMENT (CONVERSION COAT): CHEMICAL PRETREATMENT THAT BONDS PRIMER TO THE METALLIC LAYER AND BOOSTS CORROSION RESISTANCE (CHEMISTRY NOT SPECIFIED IN THE USS DOCS).

METALLIC COATING: AZ50 GALVALUME® ALUMINUM-ZINC LAYER FOR LONG-TERM CORROSION PROTECTION.

STEEL CORE: 24 GA GR50 (ASTM A792 SS GRADE 50 CLASS 4), ACTUAL THICKNESS 0.0237 IN, MELTED & MANUFACTURED IN THE USA (BUY AMERICA/BUY AMERICAN COMPLIANT).



i PANEL INFORMATION

FASTENING

WOOD SUBSTRATE: USE #8-14 K-LATH SCREWS EXTENDING 1/2" BEYOND THE BACK OF THE SUPPORT MATERIAL.

STEEL SUBSTRATE: USE #12-14 SELF-DRILLING SCREWS (SUITABLE FOR SUPPORT THICKNESSES UP TO 1/2"). PRE-DRILL PILOT HOLES WHEN ATTACHING TO STEEL SUPPORTS THICKER THAN 1/2".

FASTENER SPACING: INSTALL FASTENERS 12" - 16" ON CENTER. ADJUST SPACING PER PANEL LENGTH AND LOCAL WIND-LOAD REQUIREMENTS.

PANEL LENGTH: DO NOT EXCEED 20' IN CONTINUOUS LENGTH WITHOUT PROVIDING AN EXPANSION JOINT.

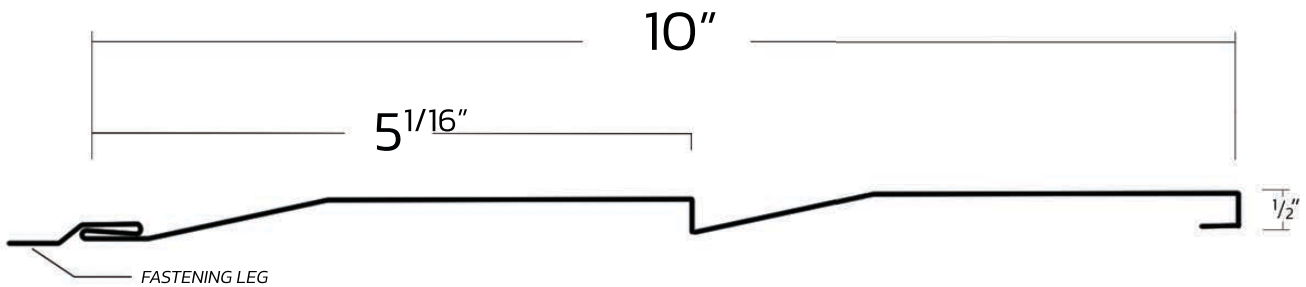
FASTENER INSTALLATION: DRIVE SCREWS PERPENDICULAR TO THE PANEL SURFACE.

PANEL ORIENTATION: INSTALL PANELS WITH THE LAP LEG POSITIONED AS SHOWN IN THE MANUFACTURER'S DIAGRAM.

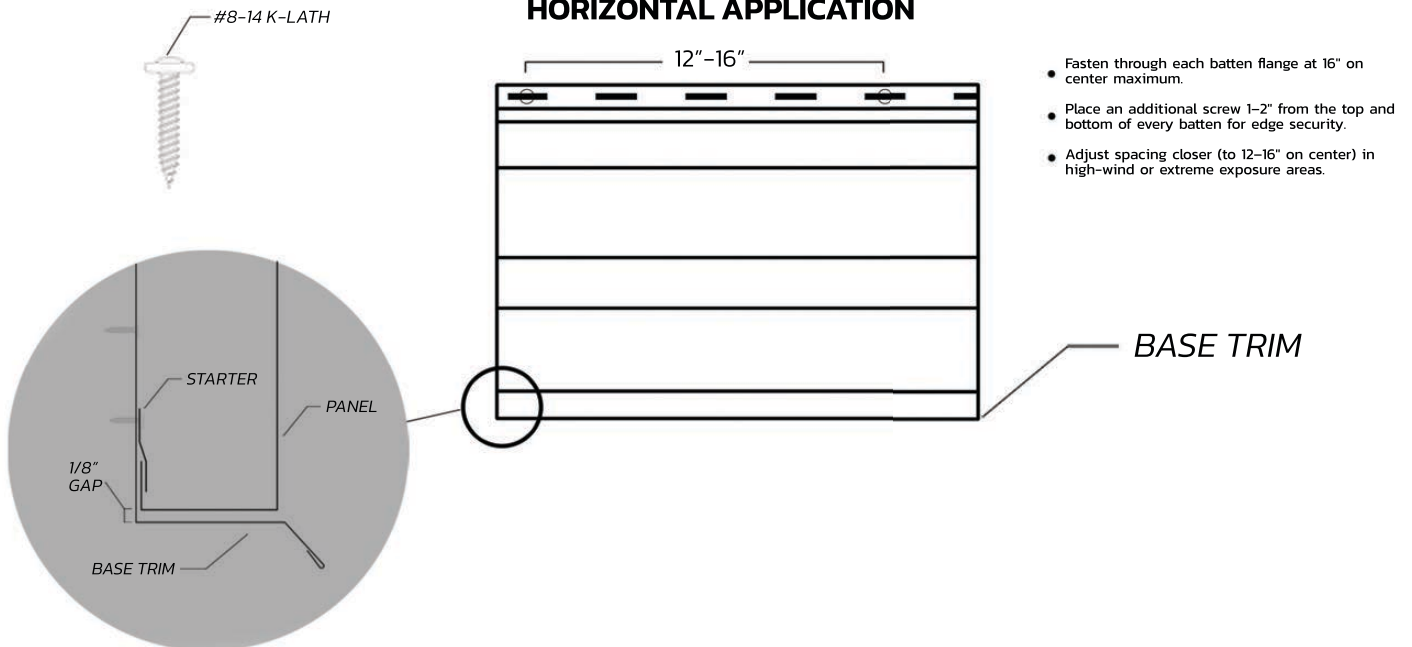


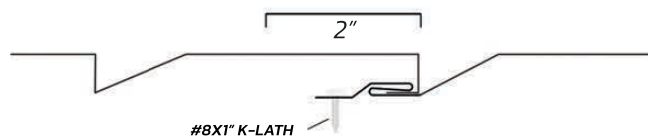
PANEL DATA

24GA GR50 AZ50, PVDF



HORIZONTAL APPLICATION





i PANEL INFORMATION

PANEL AND MATERIAL INFO

WOOD SUBSTRATE: USE #8-14 K-LATH SCREWS EXTENDING 1/2" BEYOND THE BACK OF THE SUPPORT MATERIAL.

STEEL SUBSTRATE: USE #12-14 SELF-DRILLING SCREWS (SUITABLE FOR SUPPORT THICKNESSES UP TO 1/2"). PRE-DRILL PILOT HOLES WHEN ATTACHING TO STEEL SUPPORTS THICKER THAN 1/2".

FASTENER SPACING: INSTALL FASTENERS 12-16" ON CENTER. ADJUST SPACING PER PANEL LENGTH AND LOCAL WIND-LOAD REQUIREMENTS.

PANEL LENGTH: DO NOT EXCEED 20' IN CONTINUOUS LENGTH WITHOUT PROVIDING AN EXPANSION JOINT.

FASTENER INSTALLATION: DRIVE SCREWS PERPENDICULAR TO THE PANEL SURFACE.

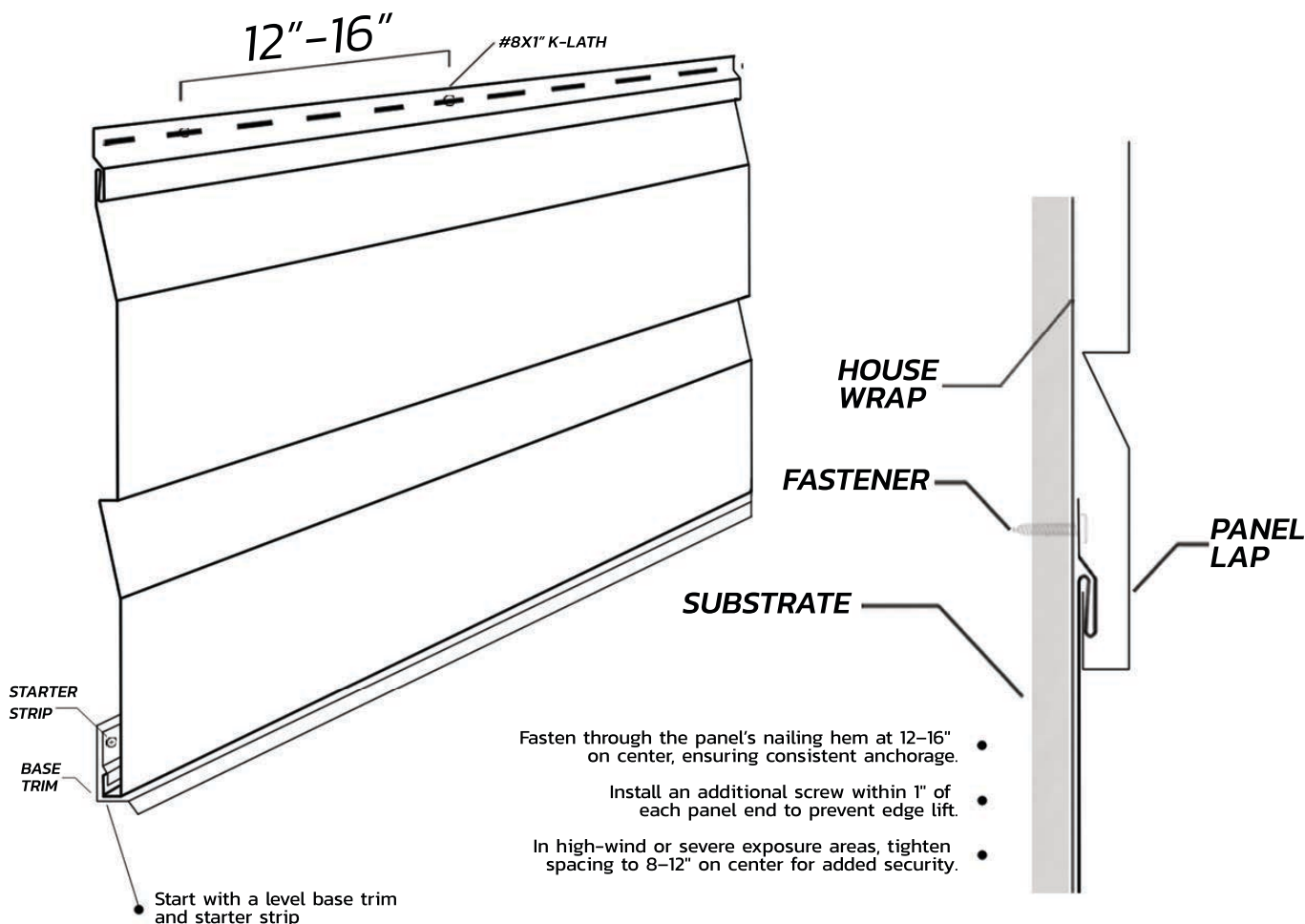
PANEL ORIENTATION: INSTALL PANELS WITH THE LAP LEG POSITIONED AS SHOWN IN THE MANUFACTURER'S DIAGRAM.

SUBSTRATE/FINISH: 24 GA GR50 AZ50, PVDF



PANEL DATA

24GA GR50 AZ50, PVDF





PROTECH STEEL
COMMITTED TO EXCELLENCE

METAL ROOFING - SIDING - TRIM

DOUBLE 5" DUTCH LAP

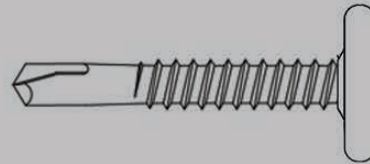
DISCLAIMER: PROTECH STEEL'S WARRANTY APPLIES ONLY WHEN YOU USE THE FASTENERS WE SUPPLY. ANY USE OF NON-PROTECH FASTENERS WILL VOID ALL WARRANTY COVERAGE.



FASTENERS

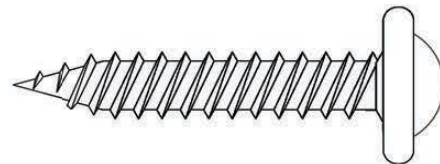
#12 CLIP SCREW

THIS SQ3 LOW PROFILE FASTENER FEATURES A SELF-DRILLING TIP, ENGINEERED TO SECURELY PIERCE AND FASTEN PANELS IN ONE STEP.



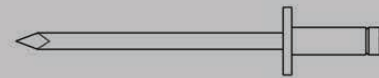
#8-14 K-LATH

THE #8x1 K-LATH TRUSS-HEAD SCREW IS SMALL AND LOW-PROFILE, PERFECT FOR PINNING TRIM AND SECURING LAP PANELS TO WOOD SUBSTRATES WITH PRECISION.



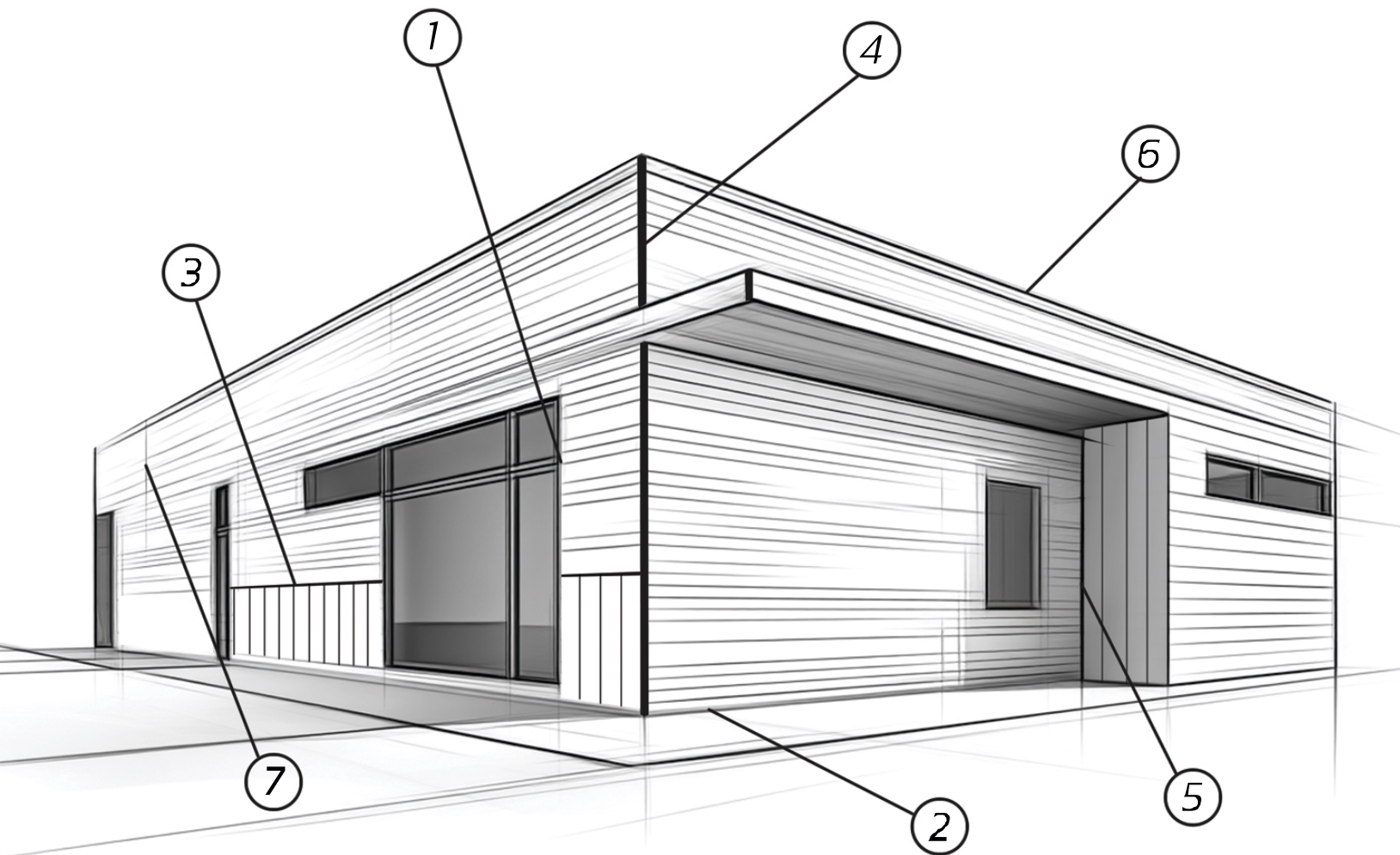
1/8" POP RIVET

THE 1/8" POP RIVET, AVAILABLE IN STAINLESS STEEL, DELIVERS A FLUSH, CORROSION-RESISTANT FASTENING SOLUTION FOR METAL PANELS, ENSURING QUICK INSTALLATION AND LONG-TERM DURABILITY.

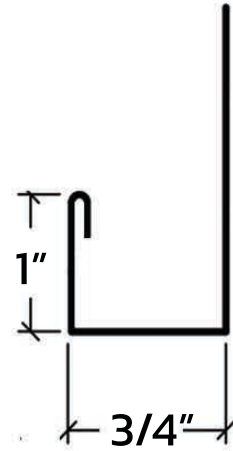


 **TABLE OF CONTENTS**

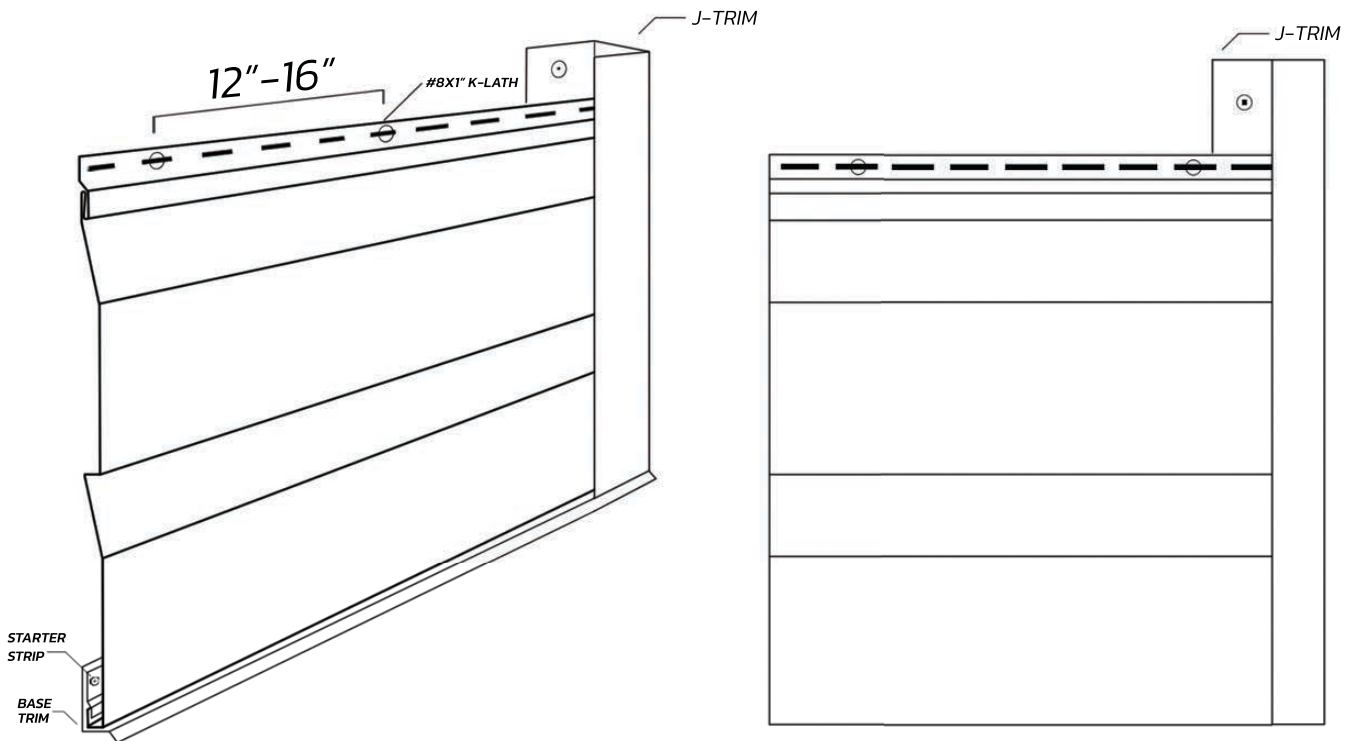
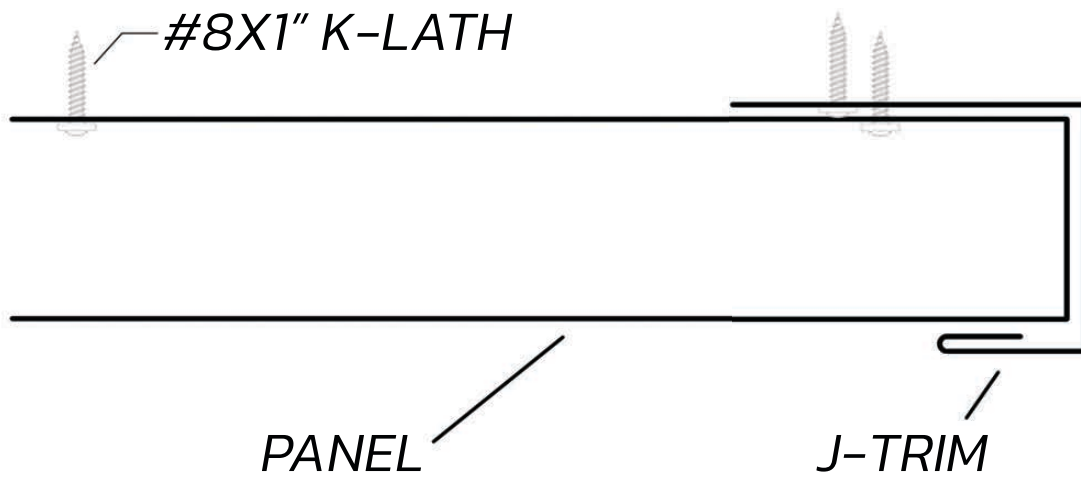
J TRIM	1
BASE TRIM	2
Z TRIM	3
OUTSIDE CORNER	4
INSIDE CORNER	5
CAP SECTION	6
EXPANSION JOINT	7

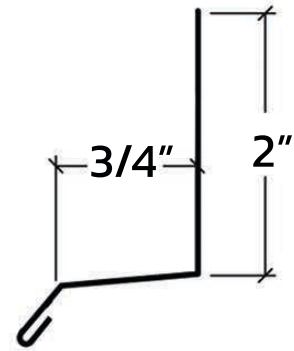


**J-TRIM
INSTALLATION**

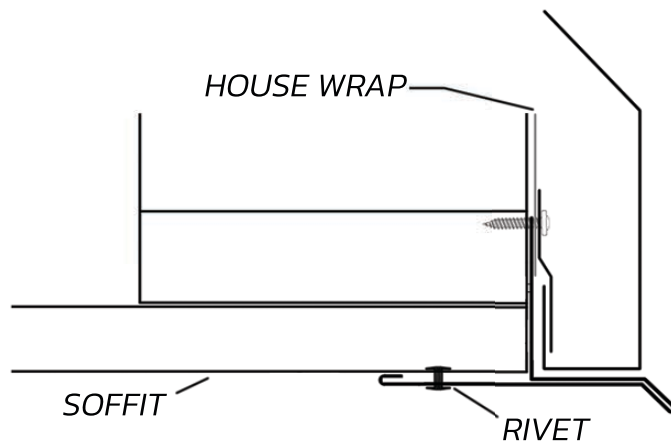
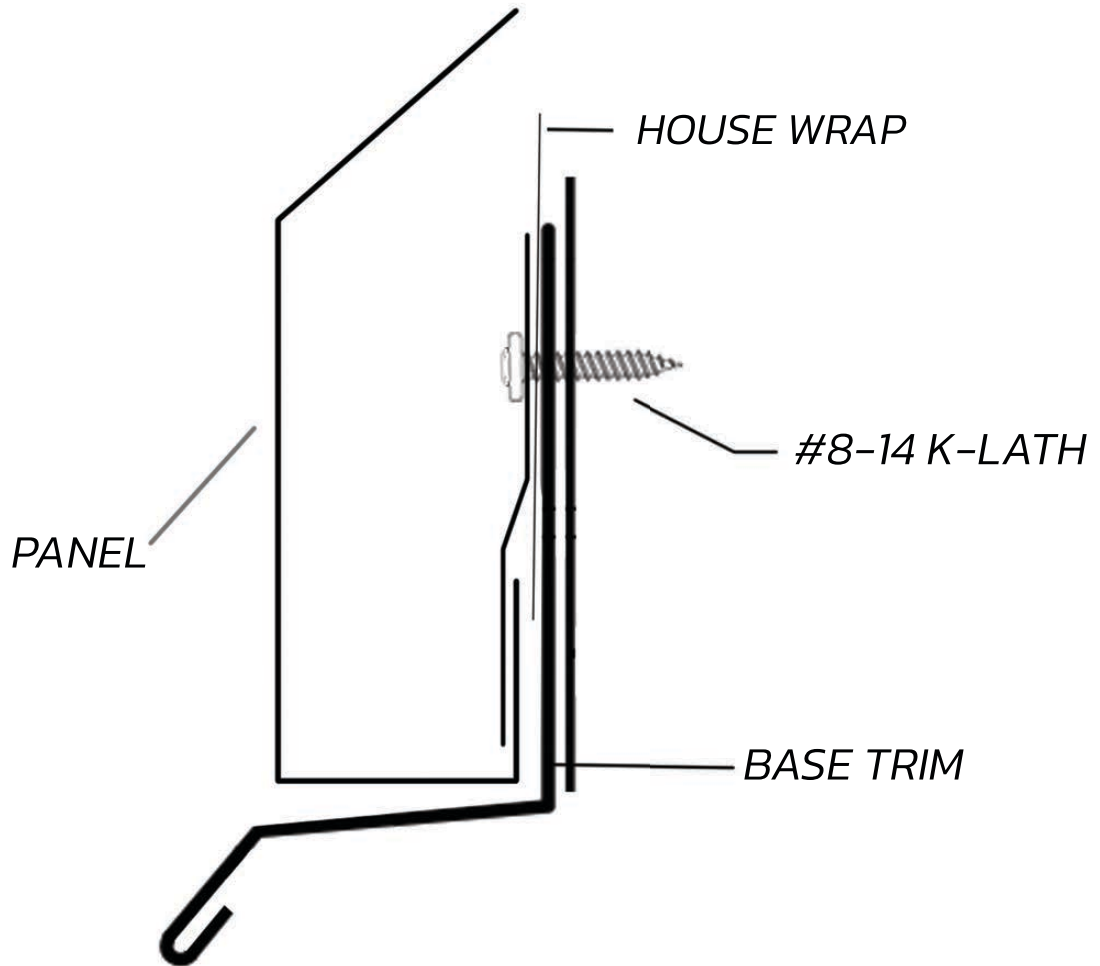


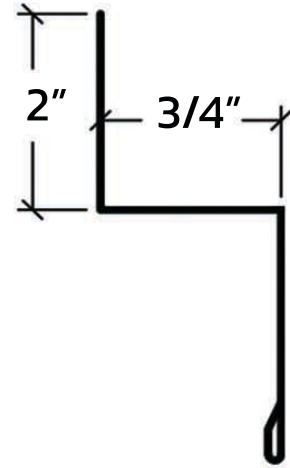
HORIZONTAL ORIENTATION



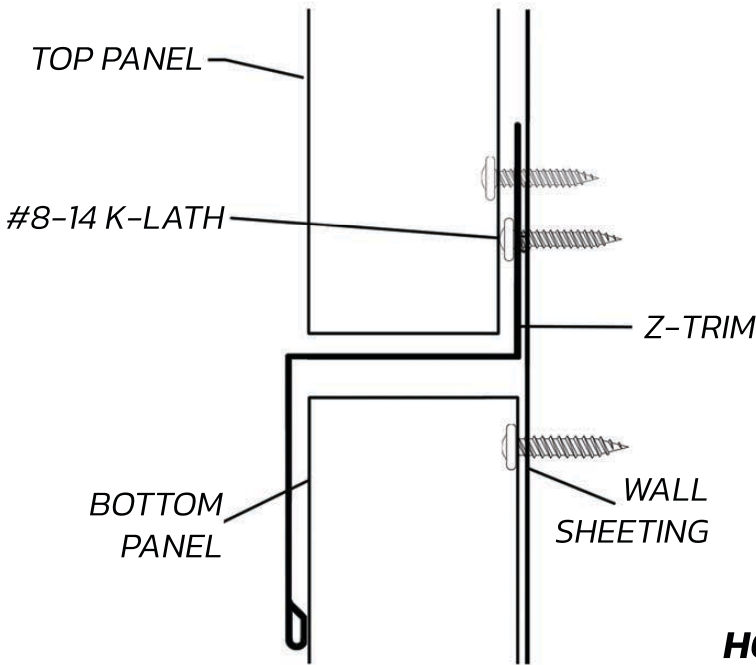


 **BASE TRIM INSTALLATION**





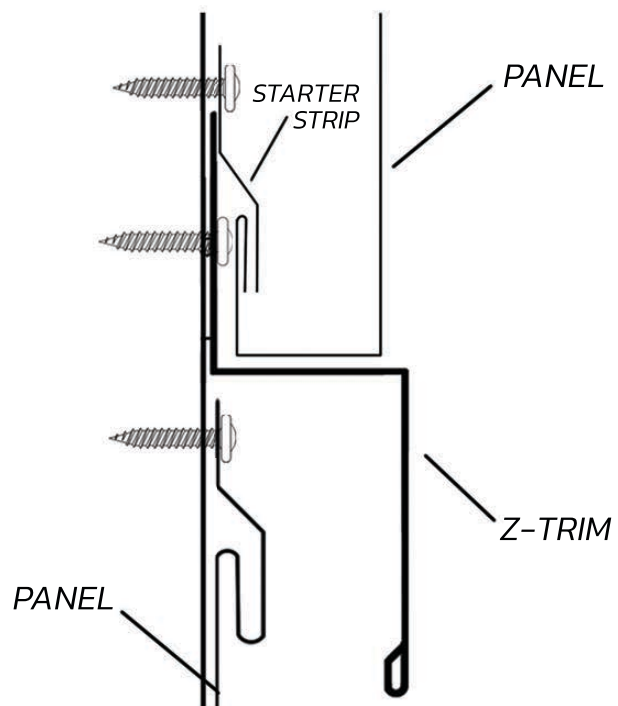
**Z-TRIM
 INSTALLATION**



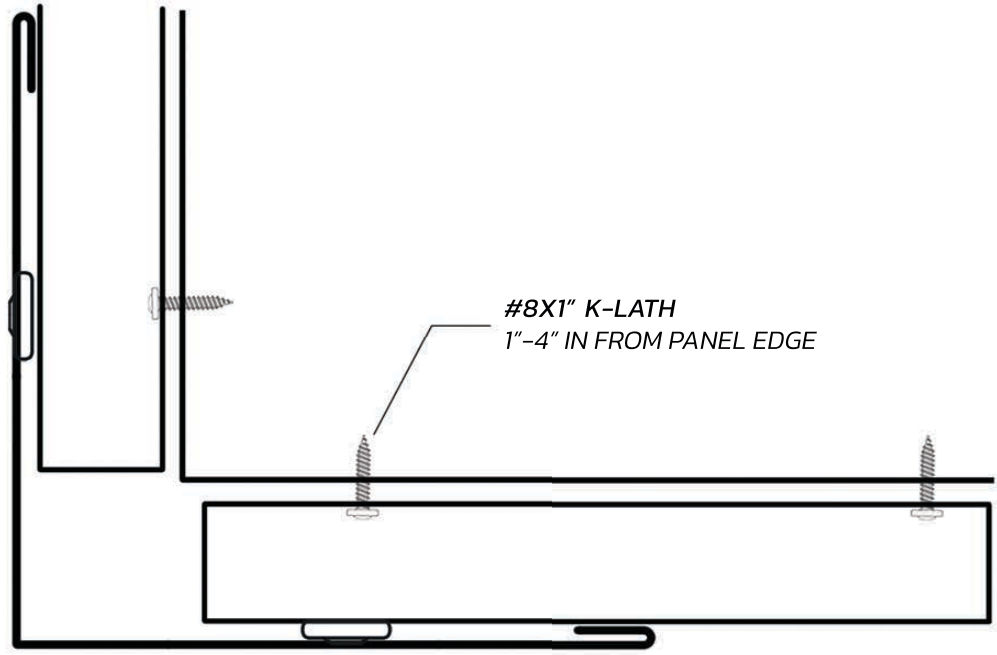
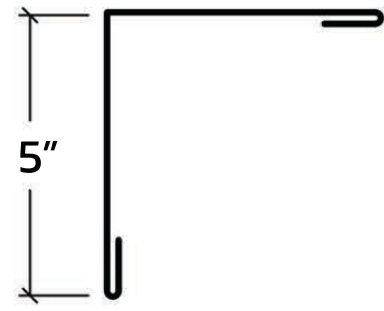
VERTICAL ORIENTATION

HORIZONTAL ORIENTATION

STARTER STRIP

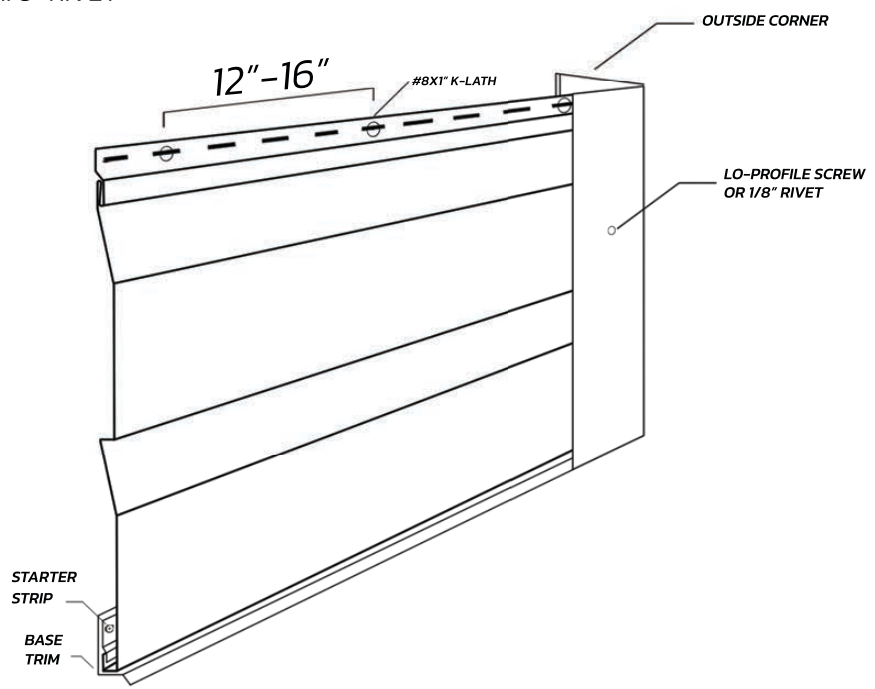


i **OUTSIDE CORNER INSTALLATION**

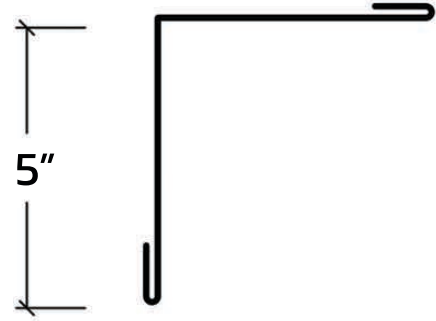


OPTIONAL
 STITCH SCREW
 LO-PRO SCREW
 OR 1/8" RIVET

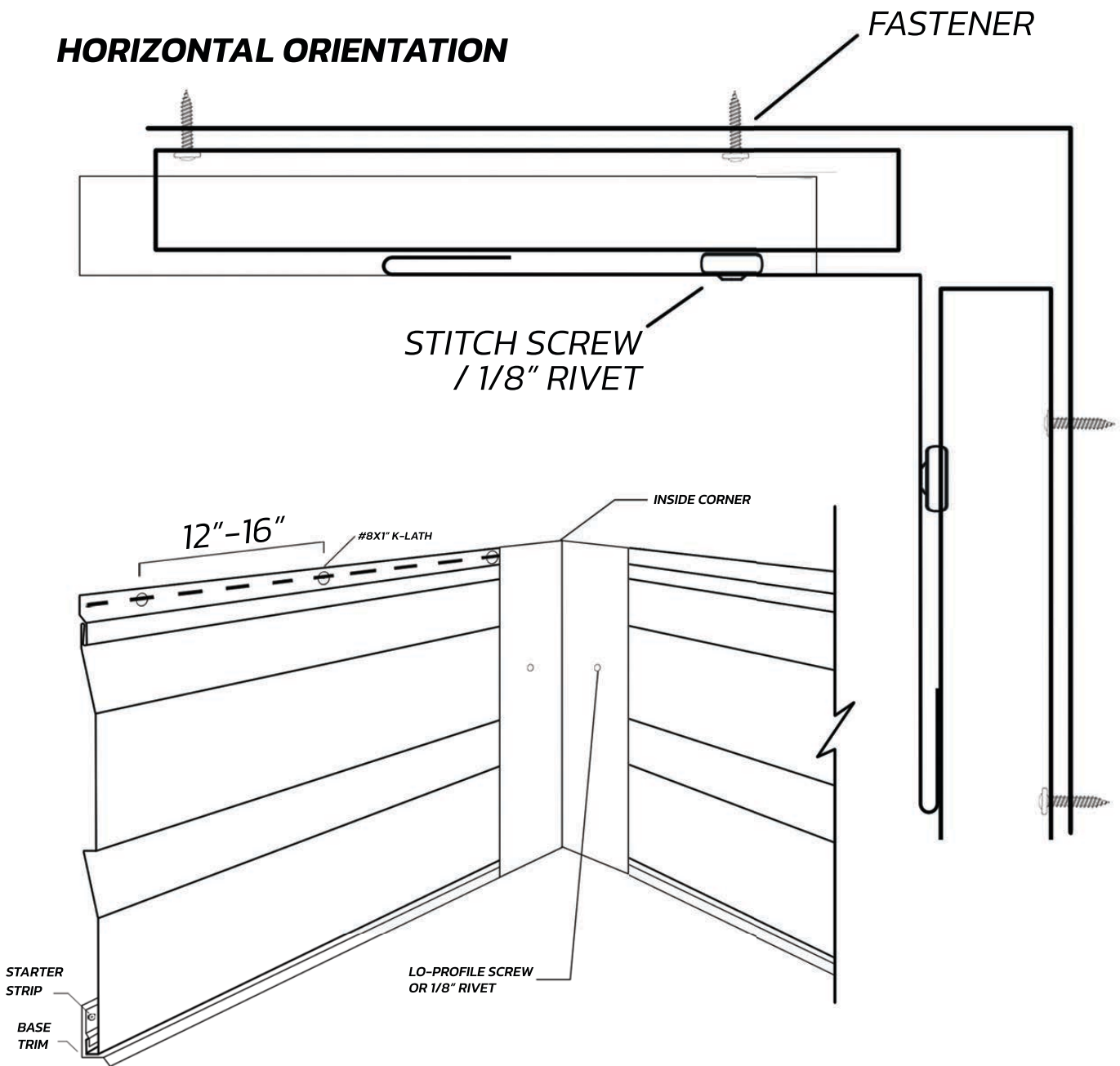
VERTICAL ORIENTATION



 **INSIDE CORNER
INSTALLATION**



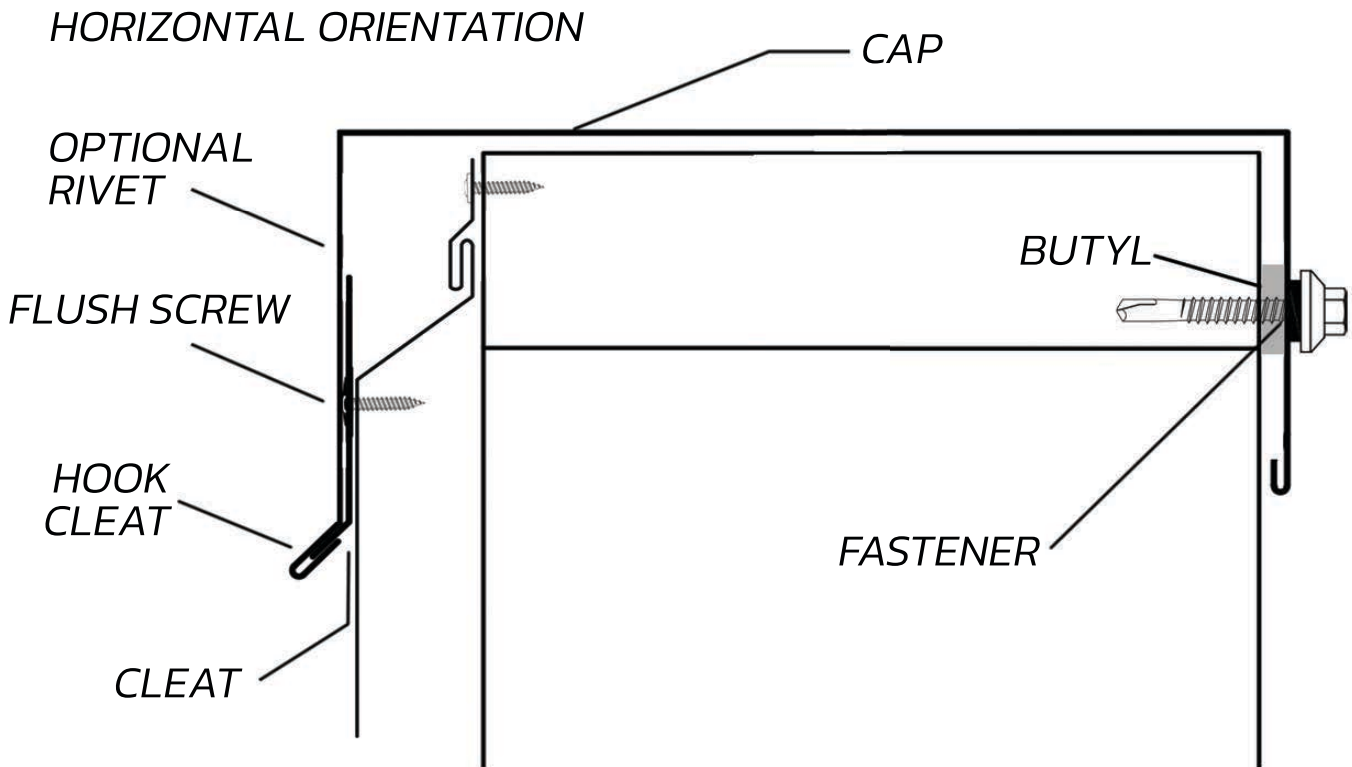
HORIZONTAL ORIENTATION

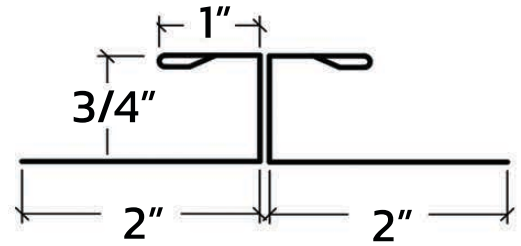


ADJUSTABLE CAP SIZES



i **CAP
INSTALLATION**





 **EXPANSION JOINT
INSTALLATION**

