

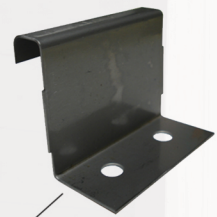

**2" MECHANICAL  
LOCK PANEL**

**INSTALLATION  
MANUAL &  
USER GUIDE**



**PANEL CLIP**

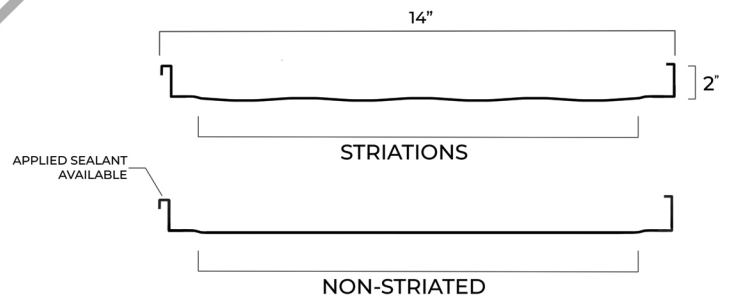

## **Table Of Contents**

- 1. COVER**
- 2. TABLE OF CONTENTS**
- 3. GUIDE OVERVIEW**
- 4. MATERIAL GUIDELINES**
- 5. GENERAL DATA SHEET**
- 6. PANEL LAP DATA**
- 7. SEAMER INFORMATION**
- 8. PANEL LAP DETAILS**
- 9. PEAK TRIM DETAIL**
- 10. EAVE TRIM DETAIL**
- 11. EAVE GUTTER DETAIL**
- 12. GABLE DETAIL**
- 13. PROW GABLE DETAIL**
- 14. RIDGE / VENTED RIDGE DETAIL**
- 15. SIDEWALL DETAIL**
- 16. ENDWALL DETAIL**

## **PROTECH STEEL GUIDE OVERVIEW**

THE DRAWINGS AND ILLUSTRATIONS IN THIS MANUAL ARE PROVIDED FOR REFERENCE PURPOSES ONLY AND MAY NOT BE SUITABLE FOR ALL BUILDING DESIGNS OR PRODUCT INSTALLATIONS. ALL PROJECTS MUST COMPLY WITH THE SPECIFIC BUILDING CODES APPLICABLE TO THEIR LOCATION. IT IS ESSENTIAL TO ADHERE TO ALL RELEVANT BUILDING REGULATIONS AND INDUSTRY BEST PRACTICES.

PROTECH STEEL WILL NOT BE HELD ACCOUNTABLE FOR THE PERFORMANCE OF THE WALL SYSTEM IF IT IS NOT INSTALLED IN ACCORDANCE WITH THE RECOMMENDATIONS IN THIS MANUAL. IN INSTANCES WHERE THERE IS A DISCREPANCY BETWEEN THIS MANUAL AND THE ACTUAL ERECTION DRAWINGS, THE ERECTION DRAWINGS SHOULD TAKE PRECEDENCE. ALL COLORS MUST BE CHOSEN FROM STEEL SAMPLES AND NOT PRINT OR ONLINE.

BEFORE ORDERING AND INSTALLING MATERIALS, ENSURE THAT ALL DIMENSIONS ARE CONFIRMED WITH FIELD MEASUREMENTS TO ENSURE ACCURACY.

PROTECH STEEL RESERVES THE RIGHT TO AMEND ANY DETAILS, RECOMMENDATIONS, OR SUGGESTIONS WITHOUT PRIOR NOTICE. IF YOU HAVE ANY QUESTIONS REGARDING THE SUCCESSFUL INSTALLATION OF THESE WALL PANEL SYSTEMS, PLEASE CONTACT YOUR LOCAL PROTECH STEEL REPRESENTATIVE. PRIOR STEEL KNOWLEDGE REQUIRED FOR PROPER INSTALLATION.

OIL CANNING, WHICH IS THE VISIBLE WAVINESS IN THE FLAT AREAS OF METAL PANELS, IS NOT CONSIDERED A DEFECT. IT IS A NATURAL CHARACTERISTIC OF LIGHT GAUGE COLD-FORMED METAL PRODUCTS, ESPECIALLY THOSE WITH BROAD, FLAT SURFACES. VARIOUS FACTORS CAN CONTRIBUTE TO OIL CANNING THAT ARE BEYOND THE CONTROL OF PROTECH STEEL, INCLUDING: MISALIGNMENT OF THE SUPPORT SYSTEM, OVER-DRIVING FASTENERS, STRESS WITHIN OR INDUCED INTO THE PANEL, THERMAL EXPANSION AND CONTRACTION, IMPROPER MATERIAL HANDLING, PANEL WIDTH, GAUGE, LENGTH, AND COLOR. SPEAK WITH ONE OF OUR PROJECT PROFESSIONALS ABOUT OILCANNING AND WAYS TO AVOID IT.

FOR ANY ADDITIONAL INFORMATION NOT COVERED IN THIS MANUAL, CONSULT YOUR LOCAL PROTECH STEEL BRANCH. THIS MANUAL IS INTENDED FOR INDUSTRY PROFESSIONALS, TO SERVE AS A GUIDE FOR SUCCESSFULLY INSTALLING A WALL PANEL SYSTEM. IT IS THE RESPONSIBILITY OF THE PROFESSIONAL OR COMPETENT INSTALLER TO ENSURE THE SAFE AND PROPER INSTALLATION OF THE PRODUCT.

FOR MORE INFORMATION OR QUESTIONS REGARDING THE INSTALLATION OF WALL PANEL SYSTEMS, CONTACT YOUR LOCAL PROTECH STEEL REPRESENTATIVE AT **1-888-21-STEEL** OR **INFO@PROTECHSTEEL.COM**.



## PROTECH STEEL MATERIAL GUIDELINES

### **PREPARATION**

BEFORE STARTING PANEL INSTALLATION, PLAN THE LAYOUT FOR ALIGNMENT WITH ADJACENT WALL SECTIONS. DECIDE IF THE FIRST PANEL WILL BE A FULL OR PARTIAL PANEL. CONSIDER THE LOCATIONS OF WALL PENETRATIONS, OPENINGS, AND THE EDGES OF THE WALL PLANE TO ENSURE A COHESIVE AND PLANNED APPROACH.

### **ORDER ACCURACY**

UPON RECEIVING MATERIALS, VERIFY THAT ALL PARTS ARE INCLUDED AND UNDAMAGED. REPORT ANY SHORTAGES IMMEDIATELY TO YOUR PROTECH STEEL CONTACT. NOTE ANY TRANSIT DAMAGE ON THE BILL OF LADING TO ENSURE ACCOUNTABILITY AND RESOLUTION.

### **SAFETY PRECAUTIONS**

ENSURE TO USE APPROPRIATE SAFETY GEAR, EQUIPMENT, AND PROCESSES DURING INSTALLATION. ESSENTIAL SAFETY GEAR INCLUDES GLOVES, ARM GUARDS, SAFETY GOGGLES, AND FALL PROTECTION. USE WELL-MAINTAINED TOOLS SUCH AS SCREW GUNS, SAWS, SNIPS, AND FOLDERS. ALWAYS BE AWARE OF POTENTIAL HAZARDS AND TAKE NECESSARY PRECAUTIONS TO AVOID ACCIDENTS.

### **MATERIAL**

NOT ALL PANELS, TRIM, TGAUGES OR LENGTHS ARE AVAILABLE AT EVERY LOCATION. CUSTOM COLORS AND NON-STANDARD MATERIALS ARE SOMETIMES SECURED PER PROJECT AND REQUIRE MINIMUM ORDER QUANTITIES. VERIFY MATERIAL AVAILABILITY WITH YOUR PROTECH STEEL REPRESENTATIVE.

### **MATERIAL STORAGE**

STORE MATERIALS INDOORS AWAY FROM THE ELEMENTS IF THEY ARE NOT IMMEDIATELY NEEDED. IF INDOOR STORAGE IS UNAVAILABLE, COVER THE MATERIALS WITH A TARP THAT ALLOWS AIR CIRCULATION. ELEVATE CRATES OFF THE GROUND AND POSITION THEM AT A SLOPE TO ENSURE WATER RUNOFF. READ AND ADHER TO ALL LABELS AND CAUTIONS ON PROTECH STEEL MATERIAL.

### **HANDLING MATERIAL**

TRANSPORT PANELS IN THEIR CRATES / STACKS TO THE INSTALLATION SITE. PROVIDE ADEQUATE SUPPORT FOR INDIVIDUAL PANELS EVERY 6 TO 8 FEET. HANDLE PANELS CAREFULLY BY GRASPING ONE SIDE AND ALLOWING THE OTHER SIDE TO HANG DOWN TO PREVENT BENDING OR WARPING.

### **PRE INSTALLATION INSPECTION**

BEFORE INSTALLING PANELS, ENSURE THE WALL SUPPORT STRUCTURE IS PLUMB, SQUARE, AND TRUE. ANY VARIANCE FROM THE PLANE SHOULD NOT EXCEED 1/4" OVER 10 FEET. PROPER ALIGNMENT ENSURES A SEAMLESS AND PROFESSIONAL INSTALLATION. PROPER PLANNING CAN SAVE TIME AND TROUBLE DOWN THE ROAD.

### **PROPER DRY-IN**

COVER THE BUILDING ENVELOPE SHEATHING WITH A MOISTURE BARRIER LIKE PROTECH STEEL SYNTHETIC UNDERLAYMENT OR PEEL AND STICK BUILDING WRAP TO RESIST AIR AND WATER PENETRATION. INSTALL THE MOISTURE BARRIER HORIZONTALLY, STARTING FROM THE BOTTOM AND OVERLAPPING EACH LAYER ABOVE THE PREVIOUS ONE TO ENSURE PROPER WATER SHEDDING.

### **FASTENERS**

AVOID OVER-TIGHTENING FASTENERS, WHICH CAN DEFORM PANELS AND TRIM. FASTENERS SHOULD SECURE THE MATERIAL JUST ENOUGH TO MAKE FIRM CONTACT BETWEEN THE SUPPORT STRUCTURE, PANEL, AND TRIM. FOLLOW THE RECOMMENDED FASTENING PATTERNS AND DETERMINE FASTENER SPACING BASED ON A LOAD ANALYSIS TO ENSURE SECURE ATTACHMENT.

### **INSTALLATION PROTOCOL**

FOR HORIZONTAL PANEL INSTALLATIONS, BEGIN AT THE BOTTOM AND WORK UPWARDS, ENSURING EACH PANEL OVERLAPS THE ONE BELOW TO ALLOW WATER RUNOFF. ENSURE ALL SURFACES HAVE AN ADEQUATE SLOPE TO PREVENT WATER ACCUMULATION. VERTICAL PANELS CAN BE INSTALLED FROM RIGHT-TO-LEFT OR LEFT-TO-RIGHT. REGULARLY CHECK FOR PROPER MODULE COVERAGE TO MAINTAIN ALIGNMENT.

### **PLASTIC WRAP**

PANELS AND TRIM ARE OFTEN PROVIDED WITH A PLASTIC FILM TO PROTECT AGAINST MINOR DAMAGE DURING FABRICATION, TRANSIT, AND HANDLING. REMOVE THE FILM JUST BEFORE INSTALLATION. DELAYING REMOVAL UNTIL AFTER INSTALLATION OR PROLONGED EXPOSURE TO SUNLIGHT OR HEAT CAN MAKE THE FILM DIFFICULT TO REMOVE.

FOLLOWING THESE GUIDELINES ENSURES A SMOOTH INSTALLATION PROCESS AND MAINTAINS THE INTEGRITY AND APPEARANCE OF YOUR PROTECH STEEL PANELS.

14" PANEL COVERAGE  
 2" RIB HEIGHT  
 CLIP SYSTEM  
 CONCEALED FASTENER  
 MECHANICALLY SEAMS

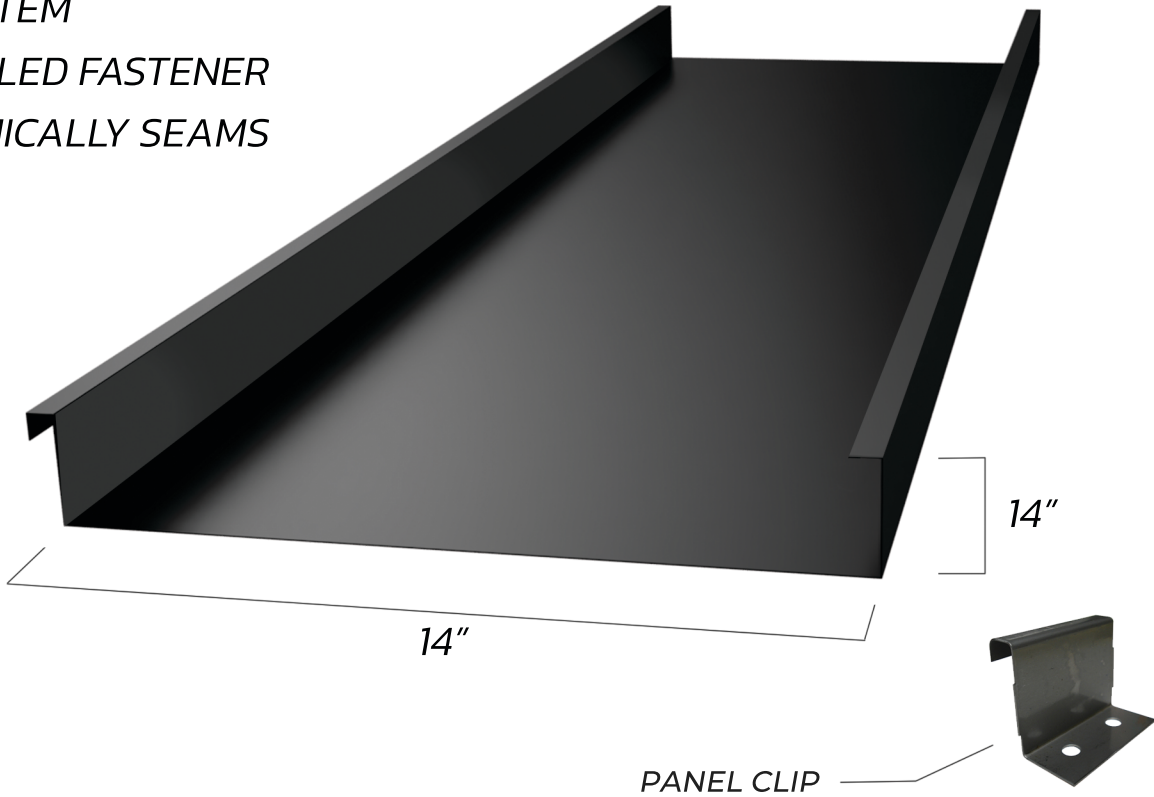

FOR USE AS ROOFING / SIDING PANEL

**\*24G, 22G PVDF/KYNAR FINISH**

\*ALTERNATE MATERIALS/FINISH AVAILABLE

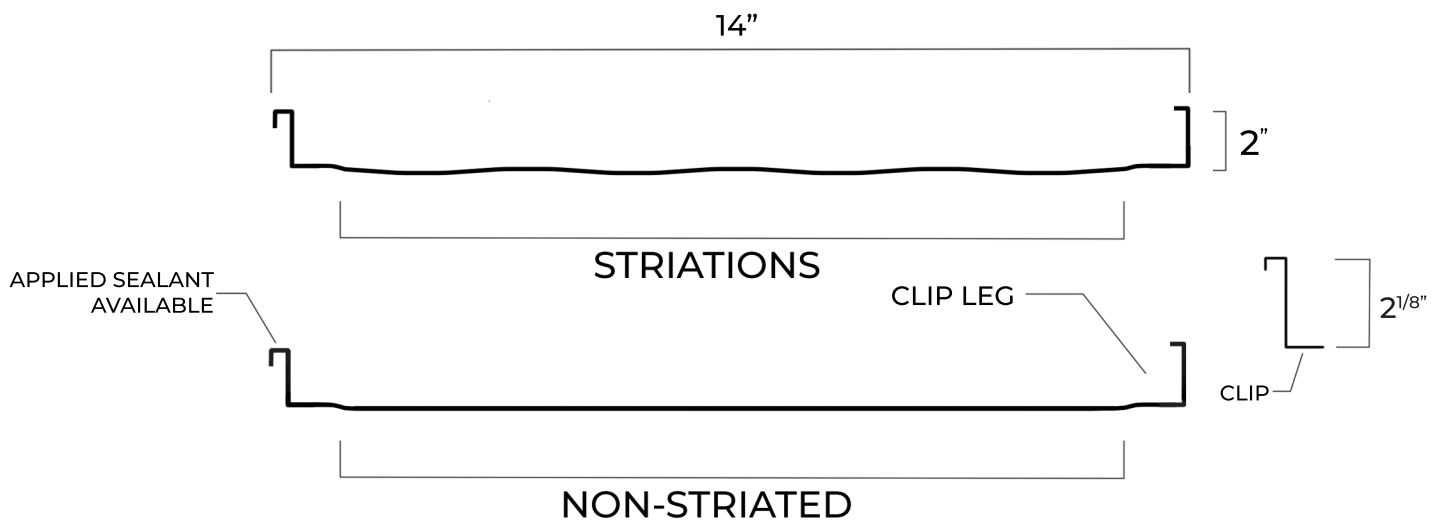

## GENERAL DATA SHEET

### LAP AND FASTENING DATA

PANEL FASTENER:  
FOR WOOD: #10-14 WOOD CLIP SCREW  
FOR STEEL: #12-14 SELF DRILLING CLIP SCREW

TRIM FASTENER:  
1/8" X 3/16" POP RIVET  
1/4"-14 X 7/8" STITCH SCREW

PANEL FASTENERS SHOULD EXTEND 1/2"  
PAST THE INSIDE FACE OF SUPPORTING MATERIAL

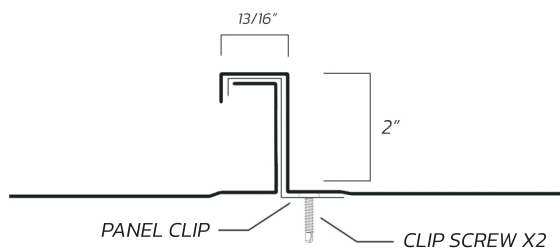

### PANEL LAP FASTENING DETAIL

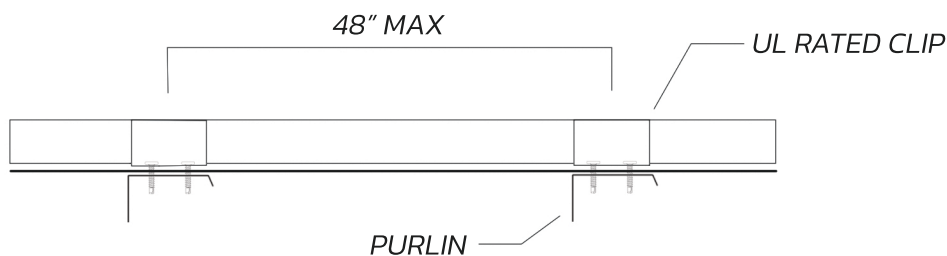
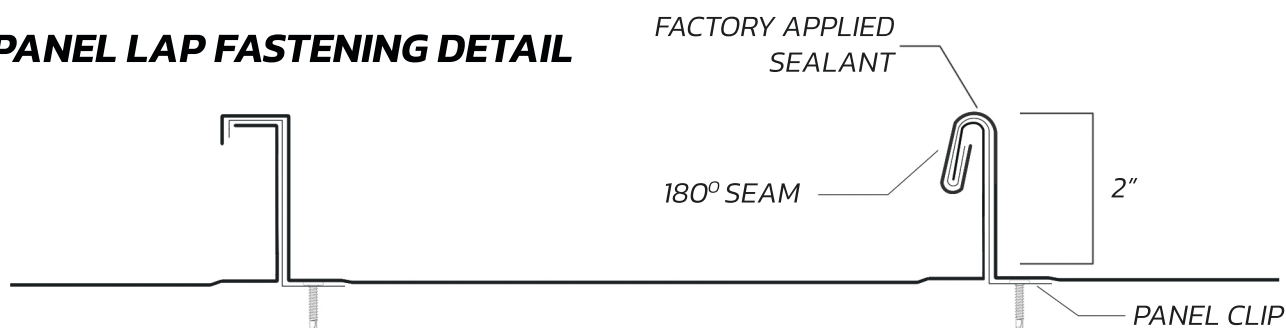

### FASTENING INFORMATION

### ADDITIONAL INFORMATION

#### FASTENER SPECIFICATIONS

WOOD SUBSTRATE: #10-14 WOOD CLIP SCREW, EXTENDING 1/2" BEYOND THE FACE OF THE SUPPORT MATERIAL.

STEEL SUBSTRATE: #12-14 SELF-DRILLING CLIP SCREW, DESIGNED FOR SUPPORT THICKNESSES UP TO 1/4".

#### TEST STANDARDS

PANEL LENGTH: PANELS CAN BE RAN ON SITE FOR LONGER THAN AVERAGE RUNS AND PANEL LENGTHS.

CLIP SPACING: 12-48 INCHES ON CENTER, WITH ADJUSTMENTS BASED ON PANEL LENGTH, ENVIRONMENTAL CONDITIONS, AND THE TYPE OF SUBSTRATE OR OPEN PURLIN SPACING.

PANELS MUST BE INSTALLED WITH THE LAP LEG POSITIONED AS SHOWN IN THE DIAGRAM. FASTENERS SHOULD ALWAYS BE INSTALLED PERPENDICULAR TO THE PANEL SURFACE.

#### ADDITIONAL NOTES:

PLAN FOR THERMAL EXPANSION BASED ON PANEL TYPE AND RUN LENGTH. EVALUATE YOUR PROJECT TO DETERMINE THE APPROPRIATE FASTENING METHOD.

FIXED CLIPS: SUITABLE FOR PANEL RUNS SHORTER THAN 20 FEET, PROVIDED THERMAL EXPANSION AND CONTRACTION ARE NOT A CONCERN. WHEN USING A FIXED UTILITY CLIP, A PANCAKE HEAD FASTENER IS REQUIRED FOR PROPER INSTALLATION.

FLOATING CLIPS: DESIGNED TO ACCOMMODATE THERMAL MOVEMENT, THESE CLIPS ALLOW PANELS TO EXPAND AND CONTRACT INDEPENDENTLY FROM THE ROOF SUBSTRUCTURE. THEY FEATURE A VERTICAL TAB THAT GLIDES ALONG THE CLIP'S BASE, ENSURING FLEXIBILITY AND PREVENTING STRESS ON THE PANELS.

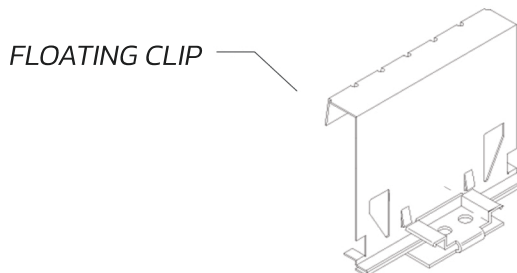
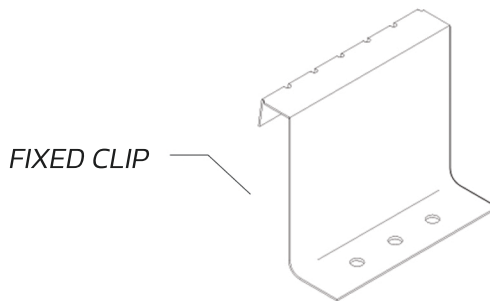



## Panel Seaming Instructions

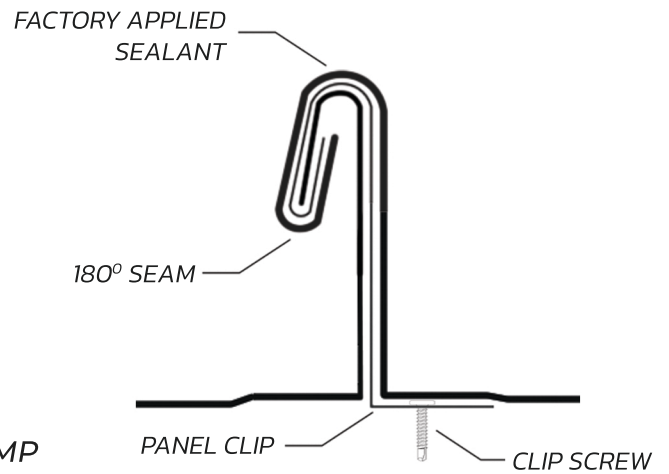
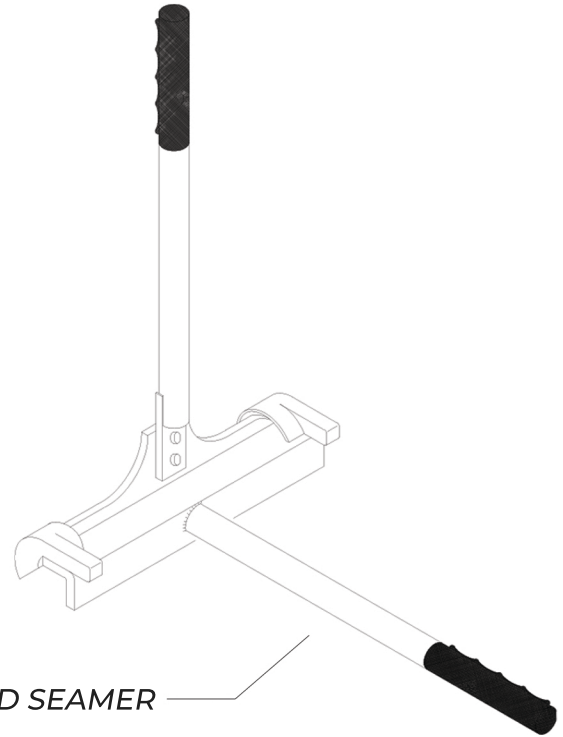
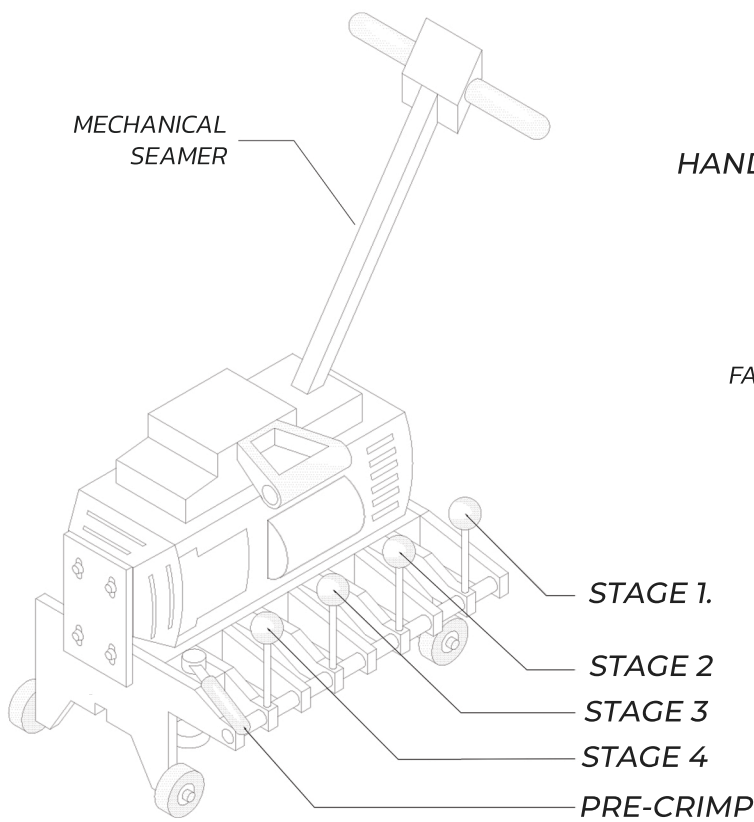

The Mechanical Lock panel system requires the use of a mechanical seamer to ensure a proper, weather-tight installation. The seamer runs from ridge to eave, working on panels installed from left to right. This process locks the panel clips and vertical legs together, increasing wind uplift resistance and overall durability.

Before using the mechanical seamer, carefully review the enclosed field manual included in the seamer case. Proper operation is critical to avoid damaging the panels or the machine. Failure to follow these instructions may result in costly damage, for which we are not responsible. More details at [diroofseamers.com](http://diroofseamers.com)

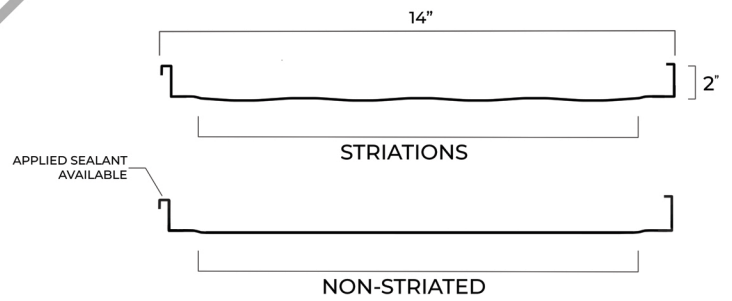

## **i** Panel Lap Detail

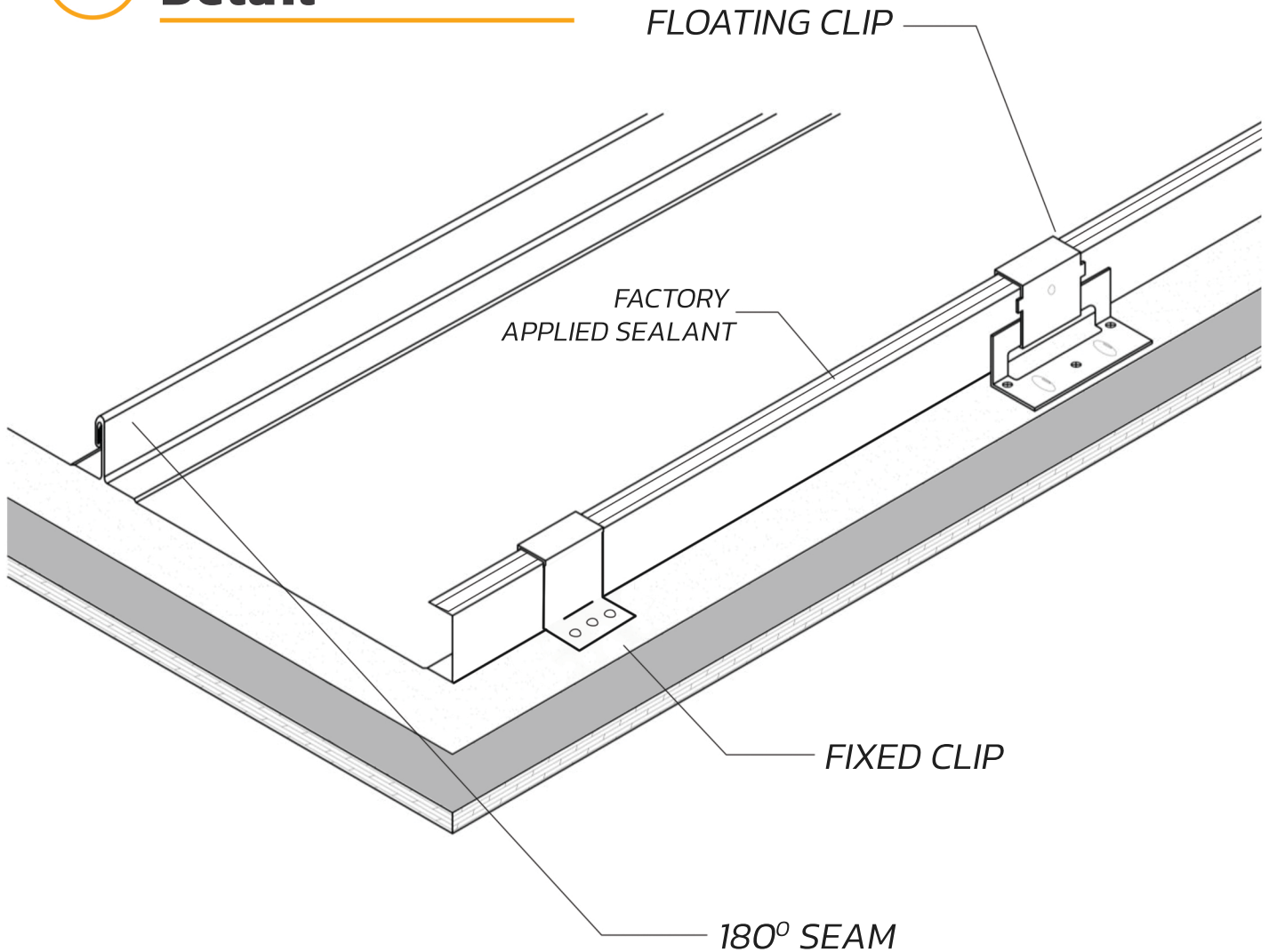

**i** The floating clip system allows for natural thermal expansion and contraction, preventing stress on the panels by enabling movement along the clip's base. In contrast, fixed clips secure the panel in place, ideal for shorter runs where expansion is minimal. To enhance weather resistance, factory-applied sealant is integrated between the lapping panels, ensuring a continuous barrier against moisture. Additionally, the 180-degree double-seamed panel is UL-approved, providing superior strength and protection in demanding conditions.

## Peak Trim Detail

**NOTE:**  
MIN. 4" LAP ON ALL FLASHING.  
APPROVED SEALANT IN ALL  
FLASHING LAPS.

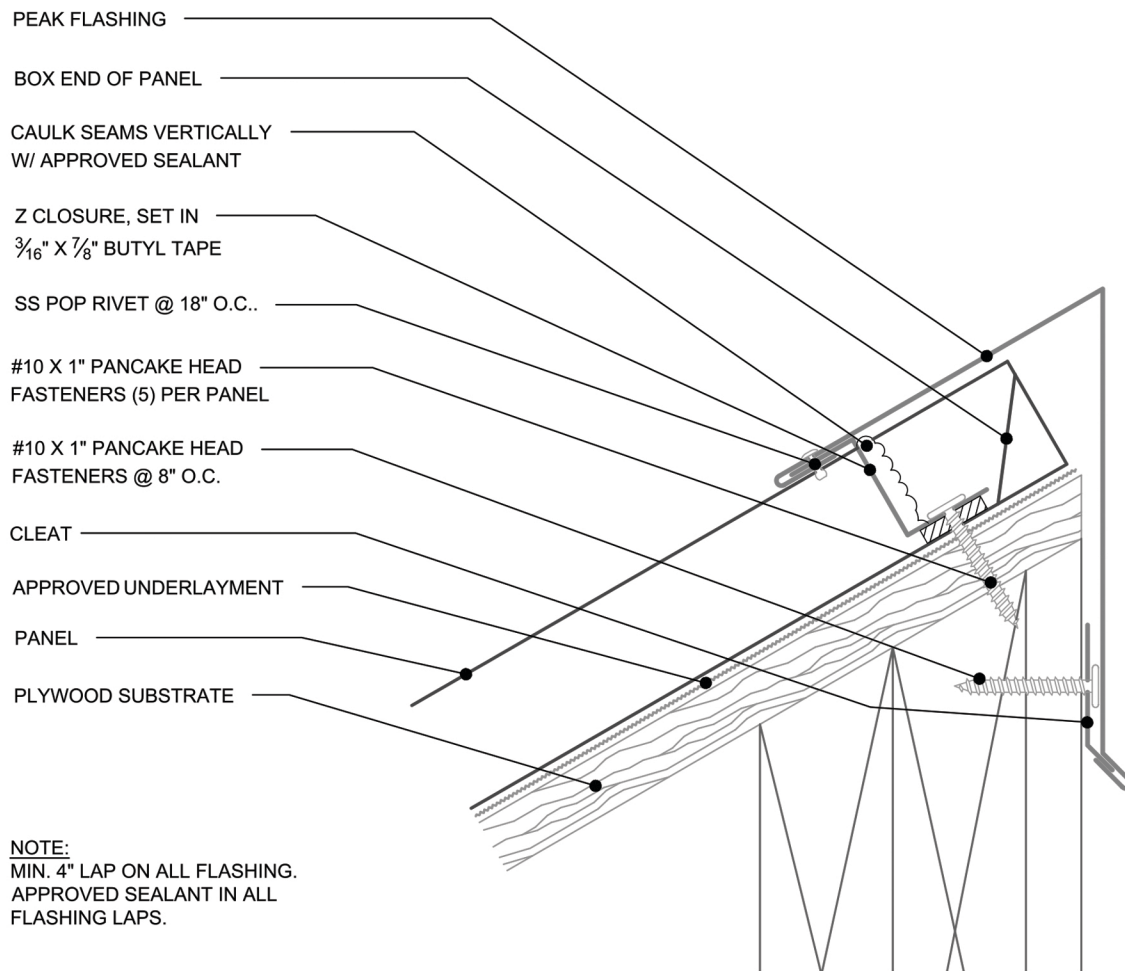

 A standard peak trim detail ensures a weathertight seal at the ridge by utilizing Z-flashing beneath the trim. If ventilation is required, the Z-flashing can be replaced with a Snap-Z ventilated steel Z-closure, allowing for proper airflow while maintaining protection against moisture. To enhance durability and prevent water intrusion, an approved sealant should be applied along the sides of the Z-flashing, ensuring a secure and long-lasting barrier against the elements.

## Eave Trim Detail

**NOTE:**  
MIN. 4" LAP ON ALL FLASHING.  
APPROVED SEALANT IN ALL  
FLASHING LAPS.

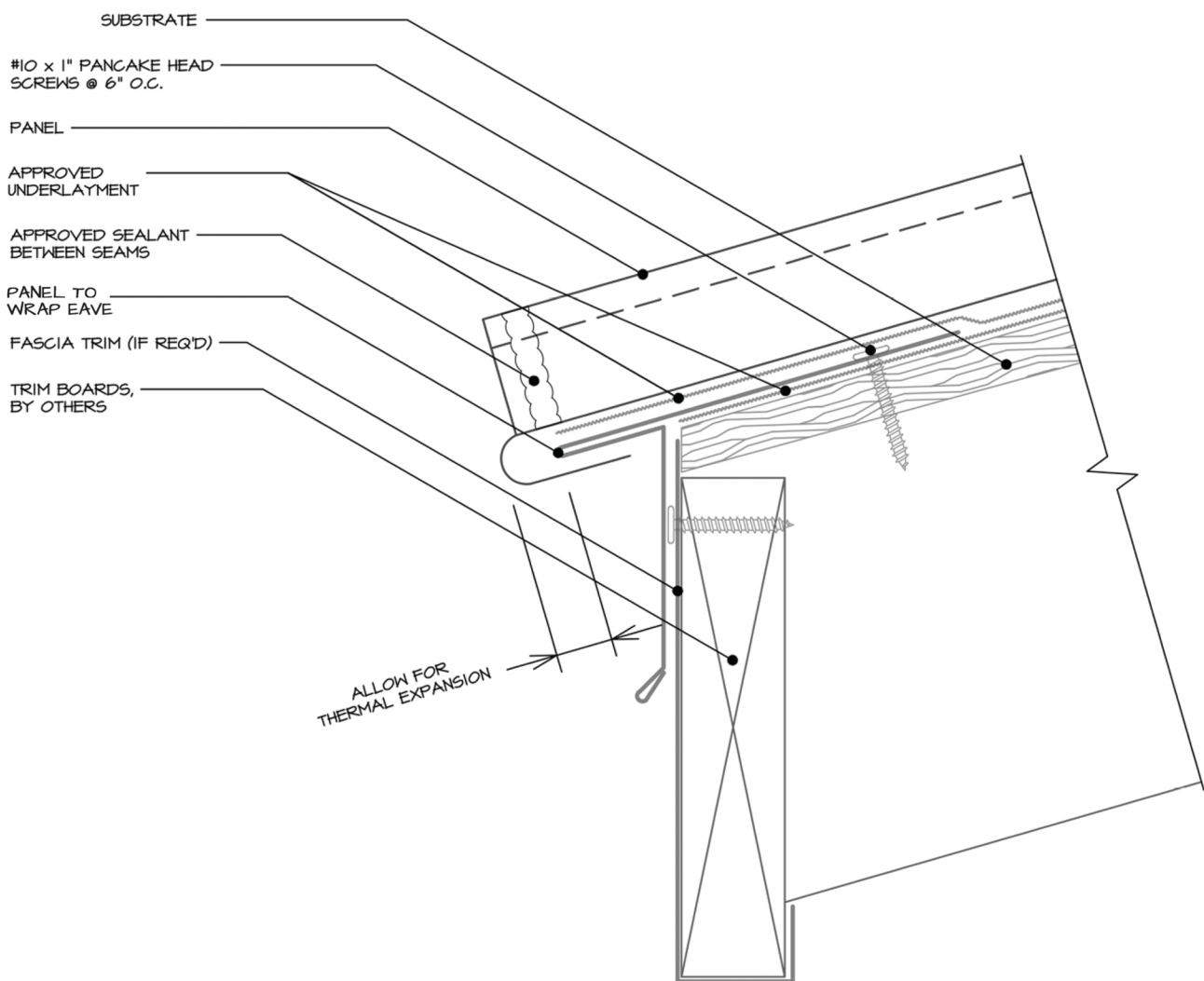

 In a simple eave trim detail, the panel edge is hemmed over a Style D trim. This creates a clean, finished edge, effectively directing water runoff away from the building's fascia without the inclusion of a gutter system.



## Gutter Eave Trim Detail

**NOTE:**  
MIN. 4" LAP ON ALL FLASHING.  
APPROVED SEALANT IN ALL  
FLASHING LAPS.

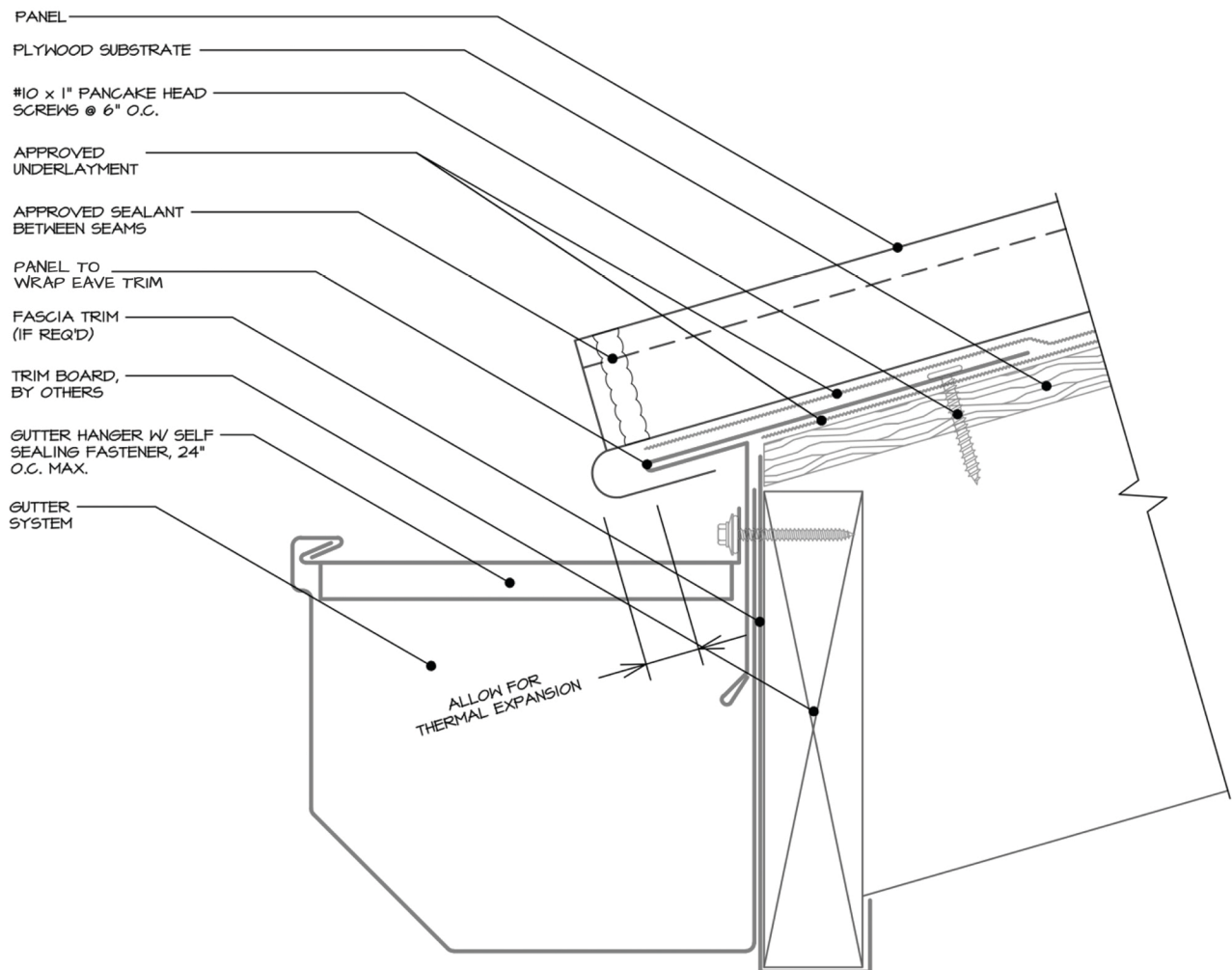



For an eave trim and gutter detail, the panel's edge is hemmed over a Style D trim.

A gutter is then positioned directly beneath the Style D. Fasteners and clips penetrate through the Style D, and gutter, securing the entire assembly and ensuring proper water drainage.

## Gable Trim Detail

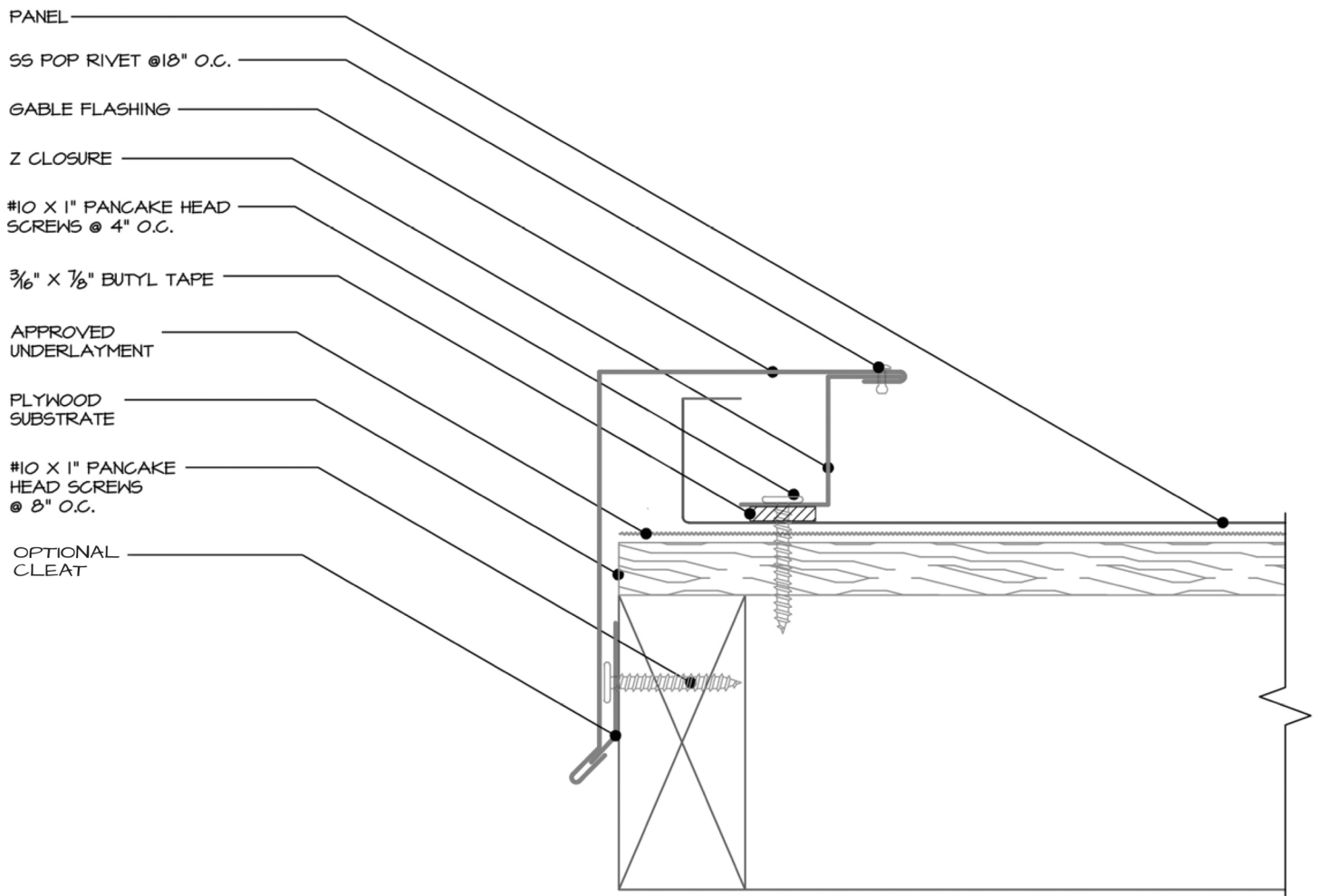
**NOTE:**  
MIN. 4" LAP ON ALL FLASHING.  
APPROVED SEALANT IN ALL  
FLASHING LAPS.



 A standard gable trim detail uses Z-flashing with the panel bent upward underneath, creating a barrier against water infiltration. This setup allows for proper drainage while maintaining a secure, watertight seal, preventing wind-driven rain from penetrating the roof edge.

## **Prow Gable Trim Detail**

**NOTE:**  
MIN. 4" LAP ON ALL FLASHING.  
APPROVED SEALANT IN ALL  
FLASHING LAPS.

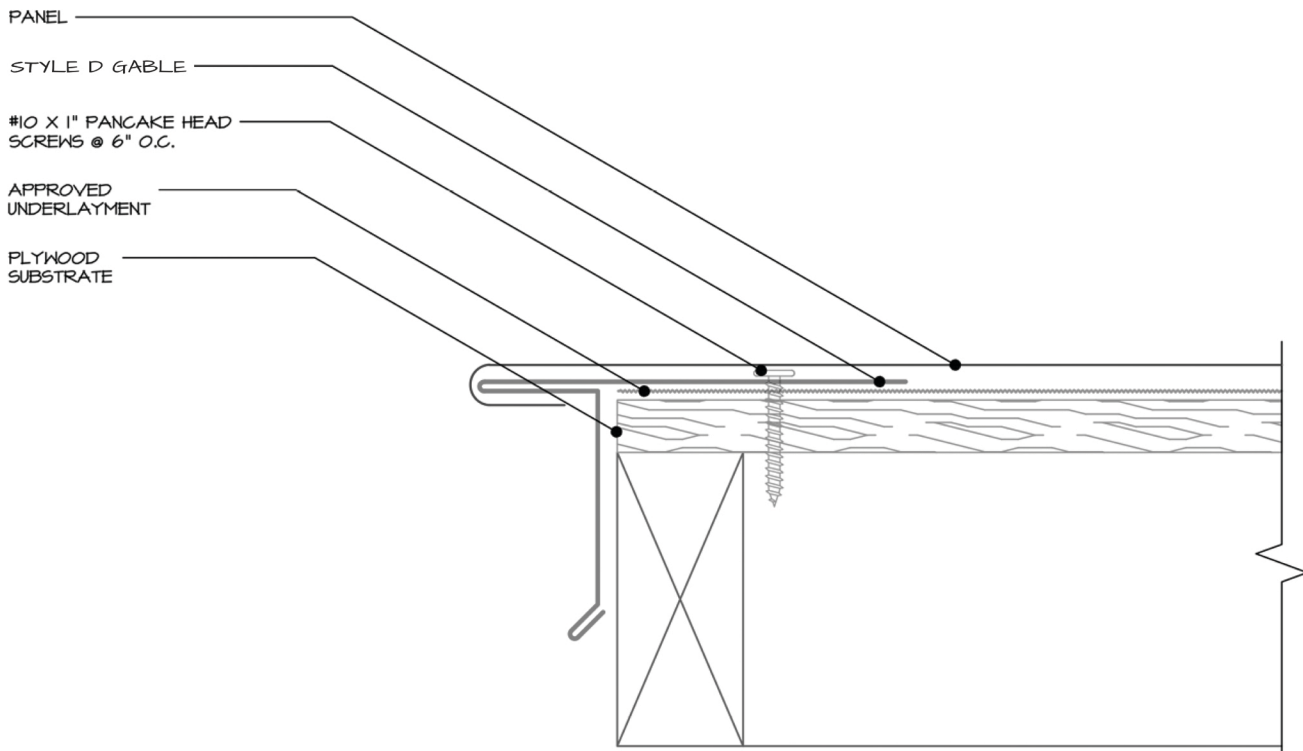

-  A prow gable allows a metal panel to be hemmed over a Style D drip edge, securing the edge while accommodating thermal expansion and contraction. This design reduces stress on fasteners and prevents distortion, all while maintaining a tight, weather-resistant seal to effectively shed water and protect the structure.



## Ridge Cap Trim Detail

**NOTE:**

MIN. 4" LAP ON ALL FLASHING.  
APPROVED SEALANT IN ALL  
FLASHING LAPS.

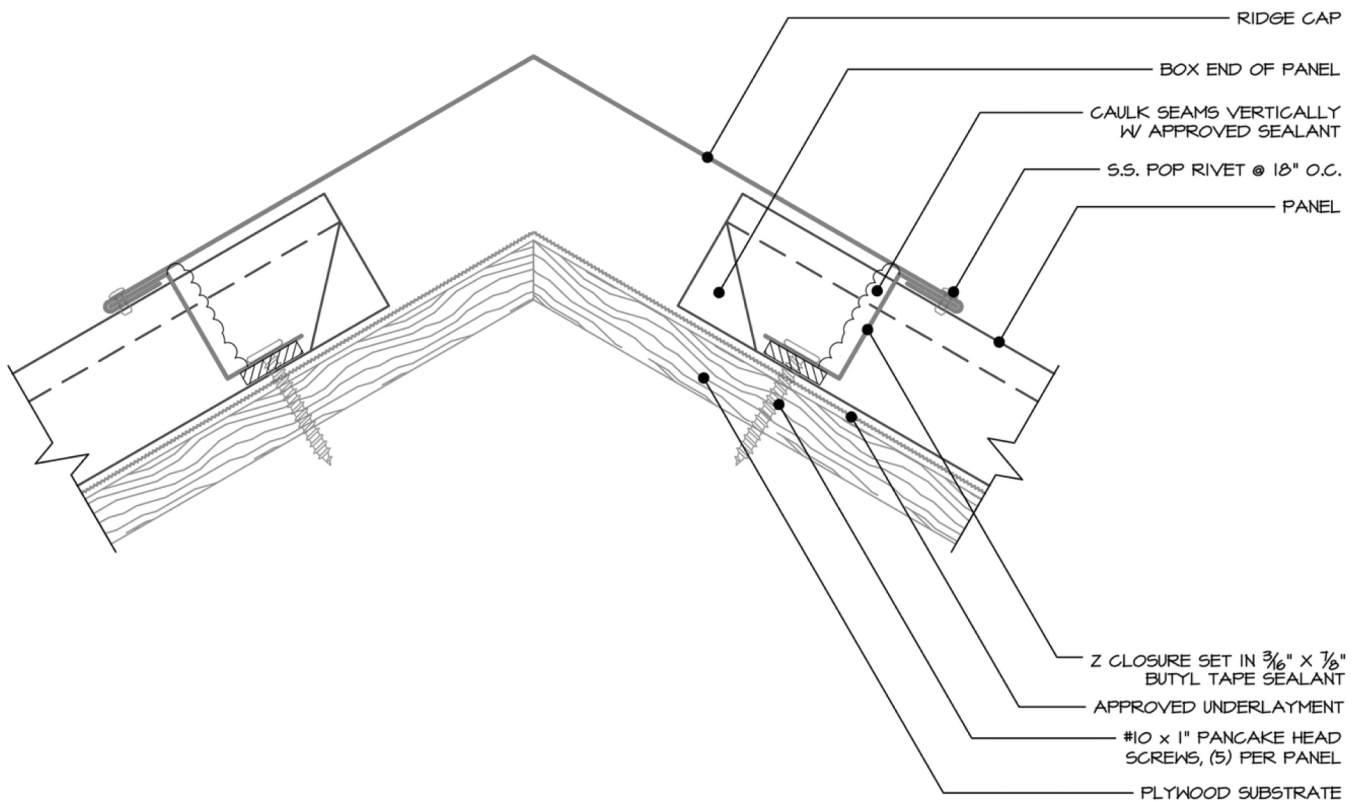



A ridge cap trim detail is designed to hug the Z-trim, creating a tight seal while being riveted in place for a secure connection. This ensures proper water shedding and structural integrity at the roof peak. For vented ridge applications, the Z-trim can be replaced with Snap-Z ventilated Z-closures, allowing for airflow while maintaining weather resistance.

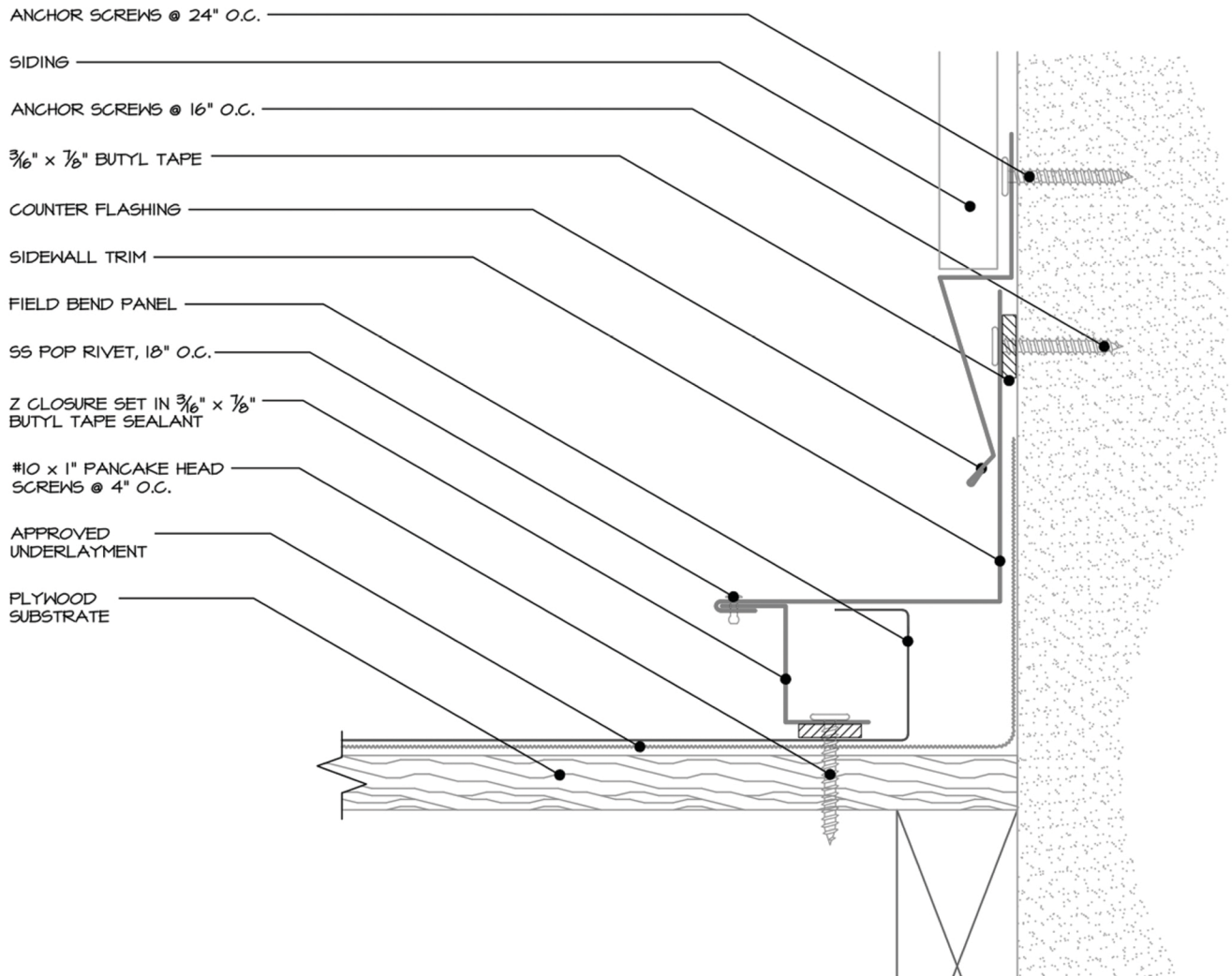

**NOTE:**  
MIN. 4" LAP ON ALL FLASHING.  
APPROVED SEALANT IN ALL  
FLASHING LAPS.

## Side Wall Trim Detail



 A sidewall trim detail employs a base flashing, crucial for preventing moisture intrusion. The base flashing is installed above the sidewall trim and extends beneath the wall panels, creating a barrier. This design effectively diverts water away from potential penetration points along the sidewall flashing, ensuring a dry and secure building envelope.



## End Wall Trim Detail

**NOTE:**  
MIN. 4" LAP ON ALL FLASHING.  
APPROVED SEALANT IN ALL  
FLASHING LAPS.

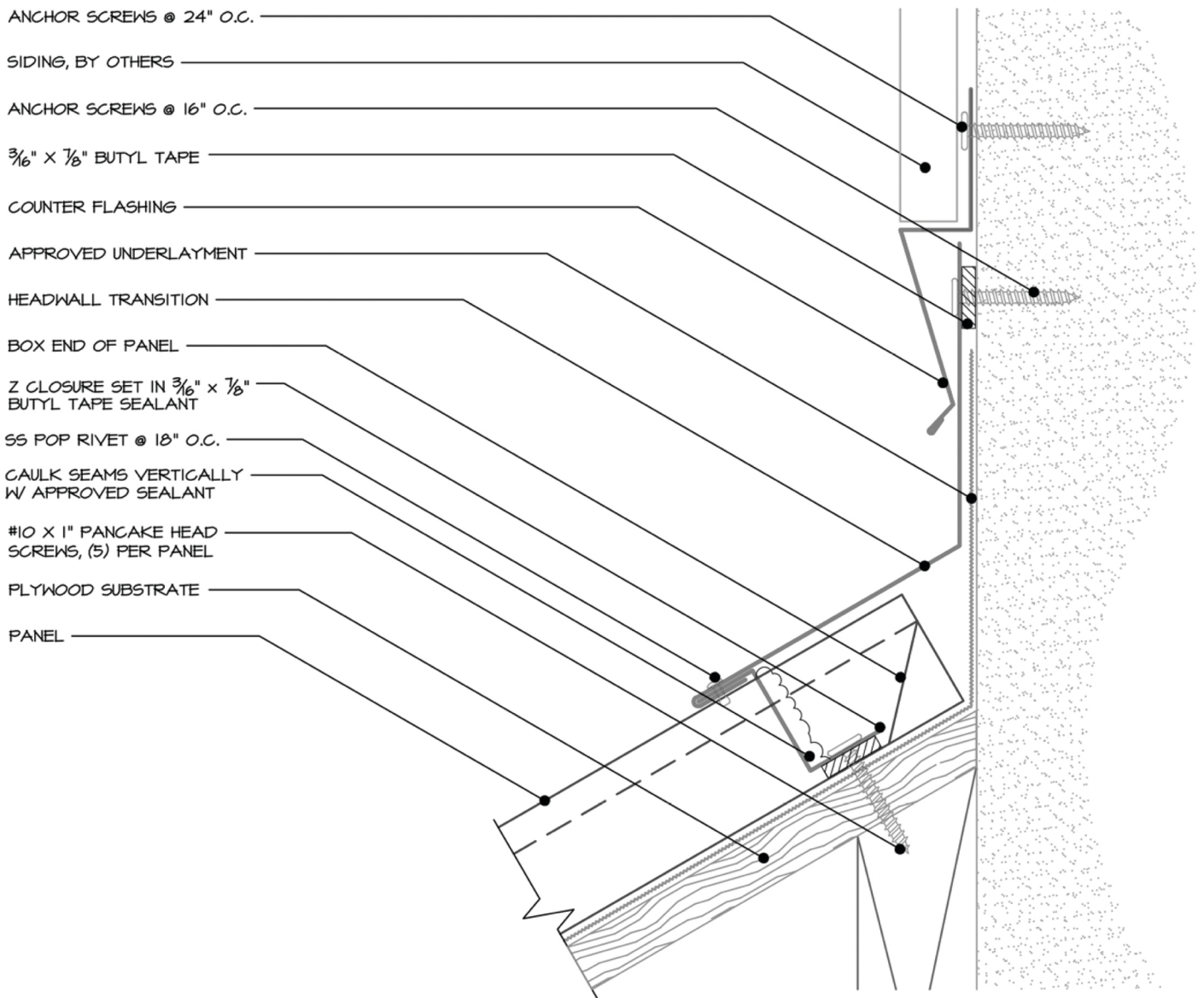

At an end wall, where panels terminate against a wall at the slope's peak, an end wall flashing is used. Crucially, a counter flashing acts as a base trim, sliding beneath the siding panels. This creates a barrier, similar to a sidewall flashing, preventing water intrusion at the panel's termination point.